

frontrow™  
pro digital



## USER GUIDE

940R Receiver

940TM Pendant Microphone

950H Pass-Around Microphone

950C Microphone Charger

# Contents

Important Safety Instructions . . . . .	1
Electrical Warnings . . . . .	2
<b>950C Charger</b>	
Chapter 1 Features . . . . .	3
Chapter 2 Charger Setup . . . . .	4
<b>940TM Pendant Microphone</b>	
Chapter 3 Features . . . . .	5
Chapter 4 Installing Battery and Charging . . . . .	6 - 7
Chapter 5 Using . . . . .	8
<b>950H Pass-Around Microphone</b>	
Chapter 6 Features . . . . .	9
Chapter 7 Setting channel, installing battery and charging . . . . .	10 - 11
Chapter 8 Using Pass-Around Microphone . . . . .	12 - 13
Chapter 9 Using a Second Transmitter . . . . .	14
<b>940R Pro Digital Receiver</b>	
Chapter 10 Features . . . . .	15
Chapter 11 Activate Receiver and Transmitter . . . . .	16
Chapter 12 Automatic Feedback Suppression and OptiVoice . . . . .	17
Chapter 13 Connecting to other Classroom Media . . . . .	18 - 19
Chapter 14 Auxiliary Output - Rebroadcasting to Personal FM Receivers . . . . .	20
Chapter 15 Troubleshooting . . . . .	21
Chapter 16 Regulatory . . . . .	22



The FrontRow Pro Digital is manufactured to conform to the most stringent European guidelines for consumer products (RoHS) – it is produced using a process free of lead and other materials harmful to the environment.



The FrontRow Pro Digital is listed with Educational Underwriters, a non-profit organization committed to serving educators seeking to meet No Child Left Behind (NCLB) requirements and to establishing best practices in education. EdU reviews the research behind educational programs and products to verify that they meet NCLB requirements and high educational standards. For additional information regarding Educational Underwriters, go to [www.educationalunderwriters.org](http://www.educationalunderwriters.org).



The FrontRow Pro Digital System conforms to the stringent electrical safety standards set by Underwriters Laboratory (UL).



Your 940TM Pendant Microphone, 950H Pass-Around Microphone, and 950C Charger use SmartCharge technology. The microphone will only charge the "silver-sleeve", auto-sensing battery that comes with our microphone. If an incompatible battery is detected, the microphone will not let you charge the battery. This prevents accidental damage.

You may use standard alkaline batteries in your microphones if you forget to charge them, but do not attempt to charge alkaline batteries separately. To ensure proper charging, always be sure that only "silver sleeve" auto-sensing batteries are installed.

# IMPORTANT SAFETY INSTRUCTIONS

1. The apparatus shall not be exposed to dripping or splashing and no objects filled with liquids, such as vases, shall be placed on the apparatus.
2. Read these instructions.
3. Keep these instructions.
4. Heed all warnings.
5. Follow all instructions.
6. Do not use this apparatus near water.
7. Clean only with dry cloth.
8. Do not block any ventilation openings. Install in accordance with the manufacturer's instructions.
9. Do not install near any heat sources such as radiators, heat registers, stoves, or other apparatus (including amplifiers) that produce heat.
10. Do not defeat the safety purpose of the polarized or grounding-type plug. A polarized plug has two blades with one wider than the other. A grounding type plug has two blades and a third grounding prong. The wide blade or the third prong are provided for your safety. If the provided plug does not fit into your outlet, consult an electrician for replacement of the obsolete outlet.
11. Protect the power cord from being walked on or pinched particularly at plugs, convenience receptacles, and the point where they exit from the apparatus.
12. Only use attachments/accessories specified by the manufacturer.
13. Use only with the cart, stand, tripod, bracket, or table specified by the manufacturer, or sold with the apparatus. When a cart is used, use caution when moving the cart/apparatus combination to avoid injury from tip-over.
14. Unplug this apparatus during lightning storms or when unused for long periods of time.
15. Refer all servicing to qualified service personnel. Servicing is required when the apparatus has been damaged in any way, such as power-supply cord or plug is damaged, liquid has been spilled or objects have fallen into the apparatus, the apparatus has been exposed to rain or moisture, does not operate normally, or has been dropped.
16. Do not use batteries that have been dropped or otherwise damaged.



# ELECTRICAL WARNINGS

## 1. Avoid Abuse to the Power Supply

To reduce risk of electric shock, unplug the power supply from outlet before attempting any maintenance or cleaning. Turn off controls will not reduce this risk.

To reduce the risk of fire or electric shock, do not expose this apparatus to rain or moisture.

**DO NOT** disassemble the power supply. Return the apparatus to Phonic Ear FrontRow for qualified service and repair if service or repair is required. Incorrect reassembly may result in a risk of electric shock or fire.

**DO NOT** expose the power supply to rain, snow, water, gas, oil, etc.

**DO NOT** operate the power supply if it has received a sharp blow, been dropped, or otherwise damaged in any way; return the apparatus to Phonic Ear FrontRow for qualified service and repair.

**DO NOT** block or cover the apparatus and impede ventilation.

**DO NOT** expose batteries (battery pack or batteries installed) to excessive heat such as sunshine, fire, or the like.

## 2. Proper Use of the Power Supply and Wiring

An extension cord should not be used unless absolutely necessary. Use of improper extension cord could result in a risk of fire and electric shock. The cord **MUST** be plugged into a grounded outlet. Make sure it is properly wired, in good electrical condition, and wire size is large enough for AC ampere rating of the power supply or charger as specified below. AWG = American Wire Gauge.

To reduce risk of damage to plug and cord when disconnecting the power supply or charger, **ALWAYS** pull on plug - **NEVER** on cord.

Locate cord so that it will not be stepped on, tripped over, or otherwise subject to damage or stress. **DO NOT** lay extension cord on charger.

**DO NOT** operate the power supply with damaged cord or plug - replace them immediately.

## ELECTRICAL SAFETY INFORMATION:



### PRECAUTIONS & SAFETY RECOMMENDATIONS

#### ***Follow Manufacturers' Recommendations***

Before using the receiver and power supply, read all instructions for, and caution markings on the receiver and power supply and in this user guide.

# 1 950C Charger

## Features

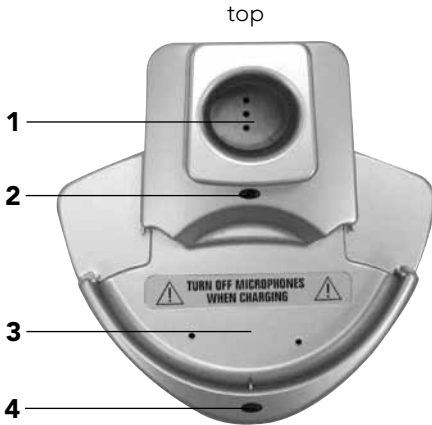

1. Charge pocket for 950H Pass-Around microphone
2. 2-way indicator light for 950H Pass-Around microphone  
No light = Pocket empty or improper battery  
Red = Charging  
Blinking red = Charge error  
Green = Charging complete
3. Charge pocket for 940TM Pendant microphone (will not charge 930TM pendant microphone)
4. 2-way indicator light for 940TM Pendant microphone  
No light = Pocket empty  
Red = Charging  
Blinking red = Faulty or improper battery  
Green = Charging complete
5. Power supply input

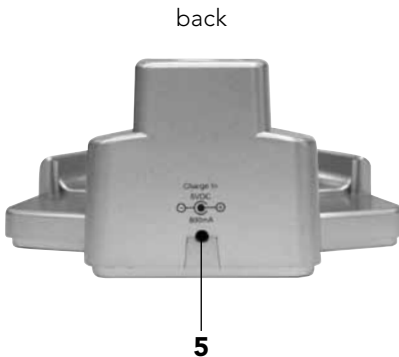

## 2 950C Charger Setup

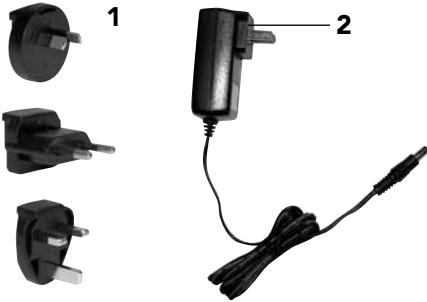

1. Find the power plug that is appropriate for the power outlet style in your country
2. Slide power plug onto the power supply
3. Plug power supply into power outlet and into the back of the charging base
4. **Charging multiple microphones**

You can charge up to 3 microphones in any configuration by connecting two chargers to the power supply. **Charging 4 or more microphones will cause the power supply to shut off.**

**NOTE:** Always connect the 950C charger to a wall outlet. Do not connect to the 940R receiver charge jack as the microphones will not charge reliably.

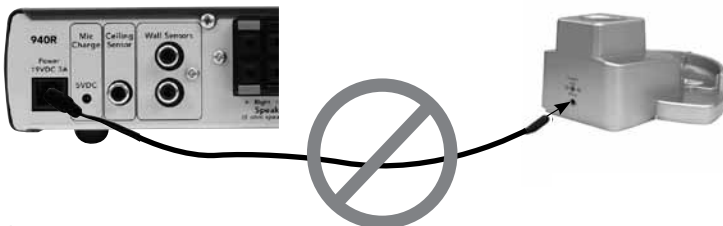
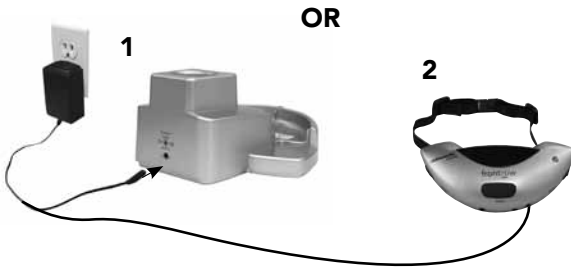
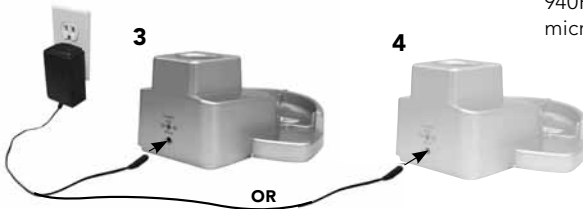

# 3 940TM Pendant Microphone

## Features

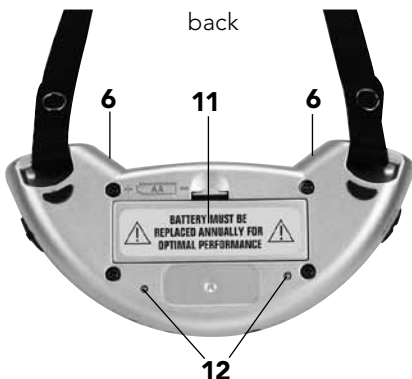
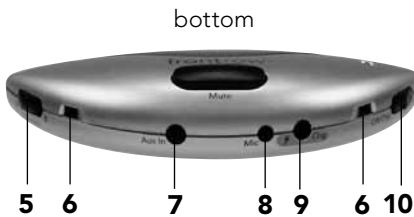
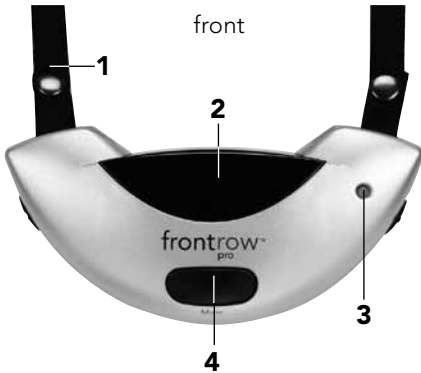

1. Neck strap
2. Infrared emitter diodes  
(Do not block)
3. Indicator Light
4. Mute button  
(Push to mute)
5. Channel selector  
(Select Channel A or Channel B.  
Cannot have two microphones on the  
same channel in the same room)
6. Microphone ports (4)  
(Do not block)
7. Aux-in audio jack  
(Use aux-in audio adaptor cord to  
send audio from a secondary audio  
source such as an MP3 player, portable  
radio/CD/tape player to the receiver)
8. External microphone jack (optional)  
(Connect a boom microphone)
9. Charge jack  
(When not using 950C charger)
10. On/off switch
11. Battery compartment  
(1) AA (LR6) NiMH rechargeable battery  
(FrontRow "silver sleeve", auto-sensing)
12. Charge contacts  
940TM only. 930TM is not supported by  
950C charger.

# 4 940TM Pendant Microphone

## Installing Battery and Charging



### Install Battery

1. Push down on tab to open battery compartment
2. Insert battery into compartment. Note polarity indicators
3. Replace battery door
4. Charge battery overnight before initial use

**IMPORTANT!** To ensure top performance and avoid equipment damage, FrontRow recommends replacing rechargeable batteries at the beginning of each school year. Do not use batteries that have been dropped or are otherwise damaged.

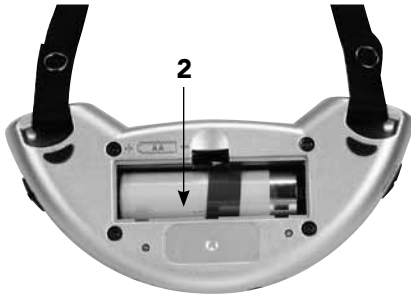

### Charge Battery Nightly

1. Indicator light will blink red when battery is low

**NOTE:** If you forget to charge your microphone at night, you may use a standard AA (LR6) alkaline battery instead. Remember to remove the alkaline battery and replace it with a FrontRow "silver-sleeve", auto-sensing battery before charging the unit.



**IMPORTANT!** In order to prevent damage to your microphone, the SmartCharge feature is intended to prevent charging of any battery other than the "silver sleeve" auto-sensing battery supplied by FrontRow. To ensure proper charging, always be sure that only FrontRow "silver sleeve" auto-sensing batteries are installed.

# 940TM Pendant Microphone

## Charging with the 2-unit charge cord

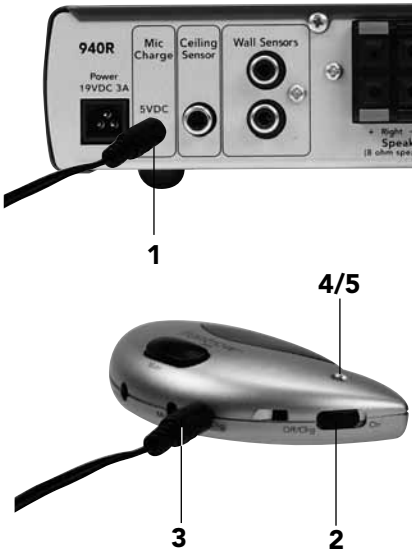

1. Plug the two-microphone charge cord into the back of the 940R receiver
2. **Turn microphone off**
3. Insert one of the charge cord plugs into the charge jack
4. The microphone indicator light should be red when charging. If it is **OFF**, check microphone battery and ensure charge cord is properly connected to microphone and receiver
5. To prolong the lifetime of the battery, the unit will enter a low-power "maintenance charge" mode after 14 hours of charging. The indicator light on the 940TM will blink red in the "maintenance charge" mode

## Charging with the 950C charger



1. **Turn microphone off**
2. Place microphone face up into the charge pocket. Ensure it is fully seated.
3. The charger indicator light should be solid red when charging. If it is **blinking red**, you are attempting to charge an alkaline battery or the battery is damaged. Replace this battery with a FrontRow "silver sleeve" NiMH cell. If the light is off, ensure charger is properly connected to power supply and that you are charging a 940TM microphone (930TM microphones cannot be charged in this charger). Re-check the seating.
4. The charger indicator light will turn green when charging is complete.

**NOTE:** Always connect the 950C charger to a wall outlet. Do not connect to the 940R receiver charge jack as the microphones will not charge reliably.

# 5 940TM Pendant Microphone

## Using

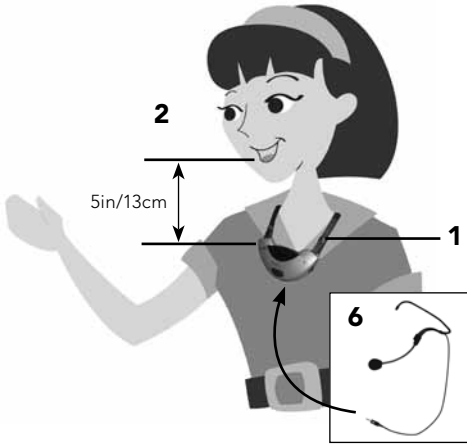

1. Place microphone around neck and connect clasp
2. Adjust neck straps to position microphone approximately 5in (13cm) from mouth
3. Set channel to A or B (whichever is not already in use)
4. Turn microphone on. Indicator light should be green
5. Press mute switch as needed for private conversations. Indicator light will blink green
6. **Optional:** if desired, plug in external boom microphone

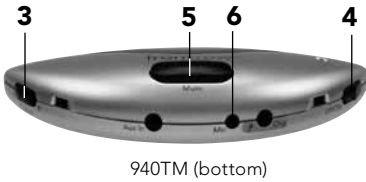

### Light Legend

- Green . . . . . On
- Blinking Green . . . . Muted
- Blinking Red . . . . . Low Battery

### When Charging with 950C charger

- No light . . . . . Charging

### When Charging with 2-unit charge cord only

- No light . . . . . Alkaline Battery is detected, or microphone power is still on
- Red . . . . . Charging
- Blinking Red . . . . . Maintenance Charge

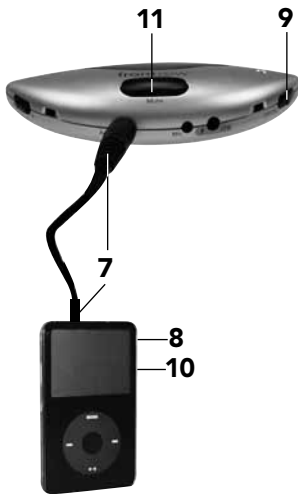

The 940TM Pendant Microphone can be used to transmit audio from a secondary audio source (MP3 player, computer, portable radio/CD/tape player) to the receiver.

7. Plug one end of the audio adaptor cord (included) in the **Audio Out/headphone jack** of the secondary audio source. Plug the other end of the adaptor cord to the **Aux-In** jack on the 940TM Pendant Microphone
8. Turn the secondary audio source on
9. Turn the 940TM Pendant Microphone on
10. Turn the volume on the secondary audio source all the way up and adjust the microphone volume on the receiver to obtain the optimal volume
11. You can "talk over" the secondary audio by speaking into the microphone or mute the microphone to ensure the best audio sound quality



# 7 950H Pass-Around Microphone

## Setting gain, channel, installing battery, and charging

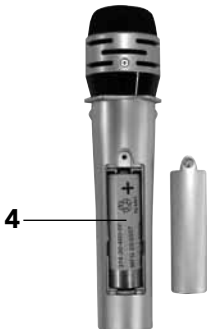

### Set gain and channel, and install battery

1. Unscrew battery door to open battery compartment
2. Set gain as follows:  
**High:** If majority of users will hold the microphone far from the mouth  
**Mid (recommended):** For most uses  
**Low:** If majority of users will hold the microphone close to the mouth
3. Set channel to A or B (Whichever is not in use)
4. Insert battery into compartment. Note polarity indicators
5. Replace battery door
6. Charge battery overnight before initial use

**IMPORTANT!** To ensure top performance and avoid equipment damage, FrontRow recommends replacing rechargeable batteries at the beginning of each school year. Do not use batteries that have been dropped or are otherwise damaged.

### Charge Battery Nightly

Indicator light will blink red when battery is low

**NOTE:** If you forget to charge your microphone at night, you may use a standard AA (LR6) alkaline battery instead. Remember to remove the alkaline battery and replace it with a FrontRow "silver-sleeve", auto-sensing battery before charging the unit.

**IMPORTANT!** In order to prevent damage to your microphone, the SmartCharge feature is intended to prevent charging of any battery other than the "silver sleeve" auto-sensing battery supplied by FrontRow. Do not attempt to charge alkaline batteries separately. To ensure proper charging, always be sure that only FrontRow "silver sleeve" auto-sensing batteries are installed.

# 950H Pass-Around Microphone

## Charging with the 2-unit charge cord



1. Plug the two-microphone charge cord into the back of the 940R receiver
2. **Turn microphone off**
3. Insert one of the charge cord plugs into the charge jack
4. The microphone indicator light should be red when charging. If it is **OFF**, ensure that you are not attempting to change an alkaline battery, and that charge cord is properly connected to microphone and receiver and 950H is **OFF**.

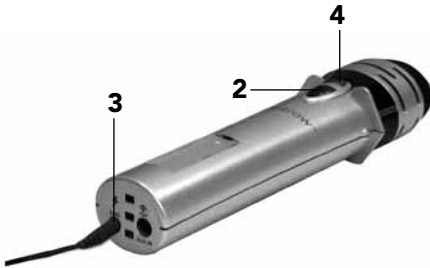

## Charging with the 950C charger

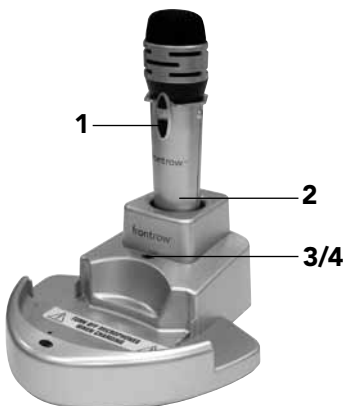

1. **Turn microphone off**
2. Place microphone into the charge pocket. Ensure it is fully seated.
3. The charger indicator light should be solid red when charging. If the light is off, ensure charger is properly connected to power supply and that you are not attempting to charge an alkaline battery.
4. The charger indicator light will turn green when charging is complete and unit will enter maintenance mode.

**NOTE:** Always connect the 950C charger to a wall outlet. Do not connect to the 940R receiver charge jack as the microphones will not charge reliably.

# 8 950H Pass-Around Microphone

## Using

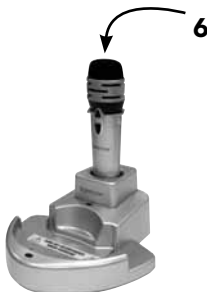
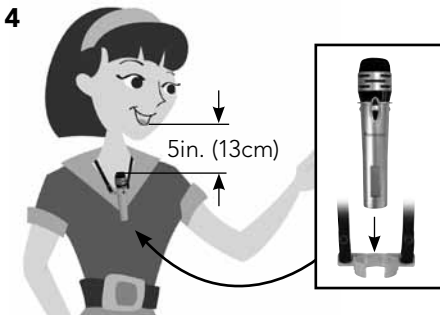
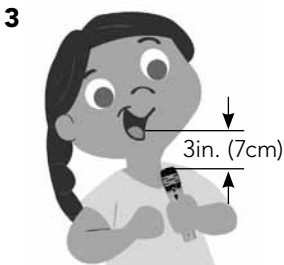
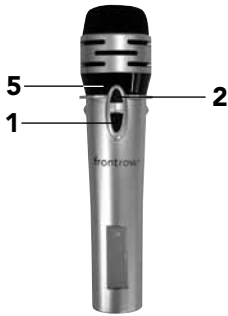

1. Turn microphone on
2. Note indicator light  
Green = On and transmitting  
Blinking red = Low battery
3. Keep top of microphone approximately 3 - 4in. (7.5 - 10cm) from mouth when using as a hand-held microphone
4. To allow hands-free use (for example, when reading aloud and turning pages), attach the lavalier clip. Adjust neck strap to position microphone approximately 4 - 5in (10 - 13cm) from mouth.
5. Do not block emitter diodes
6. Turn off microphone and place microphone in charger at the end of the day

**NOTE:** The 950H is factory set on Channel B. If you are using two microphones, they must be on different channels.

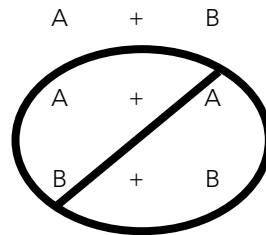

# 950H Pass-Around Microphone

## Using (cont.)

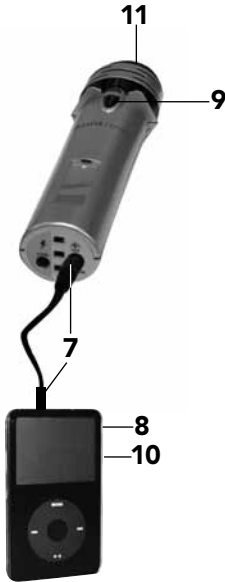

The 950H Pass-Around Microphone can be used to transmit audio from a secondary audio source (MP3 player, computer, portable radio/CD/tape player) to the receiver.

7. Plug one end of the audio adaptor cord (included) in the **Audio Out/headphone jack** of the secondary audio source. Plug the other end of the adaptor cord to the **Aux-In** jack on the 950H Pass-Around Microphone
8. Turn the secondary audio source on
9. Turn the 950H Pass-Around Microphone on
10. Turn the volume on the secondary audio source all the way up and adjust the microphone volume on the receiver to obtain the optimal volume
11. When using this feature the microphone voice audio is disabled

# 9 Using a Second Microphone

## Classroom 1



teacher 1  
(channel A)



teacher 2  
(channel B)

Your receiver is designed to receive two microphone signals at once. For example, two teachers (or a teacher and an aide) may each use a microphone. Or, one teacher can use a microphone and students can use a pass-around microphone.

Microphones must be on different channels or interference will occur.

---

## Classroom 2



teacher  
(channel A)



student  
(channel B)

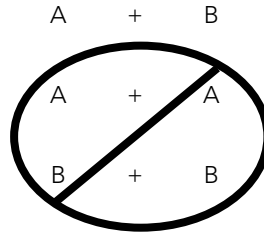

# 10 940R Pro Digital Receiver

## Features

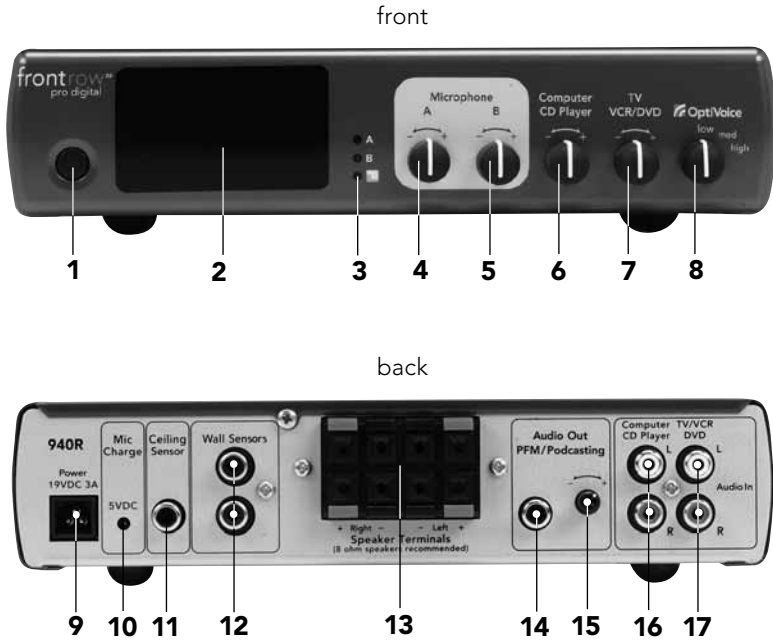

1. Power button
2. Internal infrared sensor
3. Microphone A/B and feedback suppression status lights
4. Microphone A volume control
5. Microphone B volume control
6. Aux-In audio volume control (Computer/CD player)
7. Aux-In Audio volume control (TV/VCR/DVD)
8. OptiVoice™ selector (Optimizes teacher's voice clarity for various room noise levels)
9. Power jack
10. Transmitter charge output jack (Charges up to two microphones)
11. Infrared ceiling sensor input
12. Infrared wall sensor input
13. 4 speaker terminals
14. Audio Out jack (RCA) for podcasting
15. Audio Out volume control
16. Aux-In audio jack (stereo RCA) (Computer/CD player)
17. Aux-In audio jack (stereo RCA) (TV/VCR/DVD)

# 11 940R Pro Digital Receiver

## Activate Receiver and Microphone

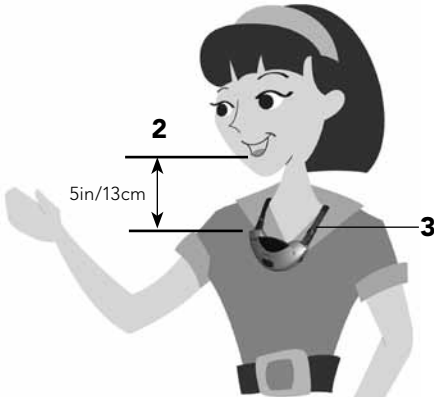
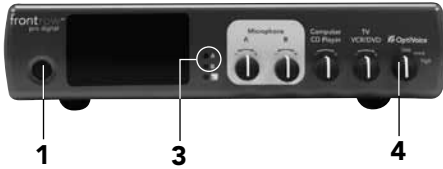

**NOTE:** When the 940R is in standby mode the external sensor LED's will blink every two seconds.

1. Press power button  
Green..... Power On  
Yellow .... Standby mode
2. Put microphone around neck and adjust strap so it is 5in. (13cm) from your mouth
3. Turn microphone on and check microphone A or B indicator light  
Green..... Power On  
Red ..... Microphone Off/Muted
4. Select proper OptiVoice level  
Low ..... Low background noise environment  
Med..... Medium background noise environment  
High..... High level background noise environment
5. Speak in a normal conversational tone while walking the entire room. Have a second person adjust the volume to a comfortable level.

### Daily Use

Your FrontRow Pro Digital has an energy-saving standby mode. The receiver will automatically go into standby mode in 10 minutes after you:

- Turn off or mute your microphone
- Stop playing a secondary audio source (computer, MP3 player, etc.)

The receiver will come out of standby mode automatically when you:

- Turn on or un-mute your microphone
- Play a secondary audio source (computer, MP3 player, etc.) connected to the receiver

Daily operation is easier than ever; the system will "wake up" and "go to sleep" automatically.

**Once the microphone and auxiliary audio volume is set to the optimal level, the only thing you need to remember is to turn the microphone on in the morning and turn it off and charge it in the evening.**

**To play auxiliary audio through the system, you simply need to press "play" on your auxiliary audio source and "stop" when you are finished.**

# 12 940R Pro Digital Receiver

## Automatic Feedback Suppression and OptiVoice



The FrontRow Pro Digital features automatic feedback suppression. The Adapto™ platform analyzes the sound quality hundreds of times a second, looking for signs of feedback. When feedback is detected, it filters it out, allowing the teacher to have optimal volume settings AND complete freedom of movement around the classroom.

When the automatic feedback suppression is active, the Adapto light (1) on the front panel will turn green. It may turn on and off throughout the day, but that is OK; it just means that it is working to optimize sound quality.

When adjusting the volume the goal is speech clarity, not rock concert power and volume. As a general rule, you should barely hear your own voice through the system when speaking.

**NOTE:** Feedback may still occur if the volume is turned up very high – too high for sensible classroom use. If this occurs, turn volume down in small increments until the feedback disappears.



A powerful tool for test-taking, directions, and ESL instruction. Fragile consonant sounds carry about 75% of the meaning in speech but are easily destroyed by background noise. OPTIVOICE strengthens these critical sounds, doing the work of a 12-band equalizer with a single switch (2).

For low background noise environments and for a more natural reproduction of your voice, use the low setting. For environments with higher background noises, use the medium or high setting. Experiment with the right mix of microphone volume and OPTIVOICE setting to find the optimal solution for your environment.



# 940R Pro Digital Receiver

## Connecting to other classroom media (cont.)

### Option 2

Some classrooms use a computer as the multi-media "hub", but it is connected to a TV instead of an LCD projector. They also occasionally use the TV/DVD/VCR as a stand alone media. For these classrooms, you may need to use both auxiliary audio input connections to the 940R.

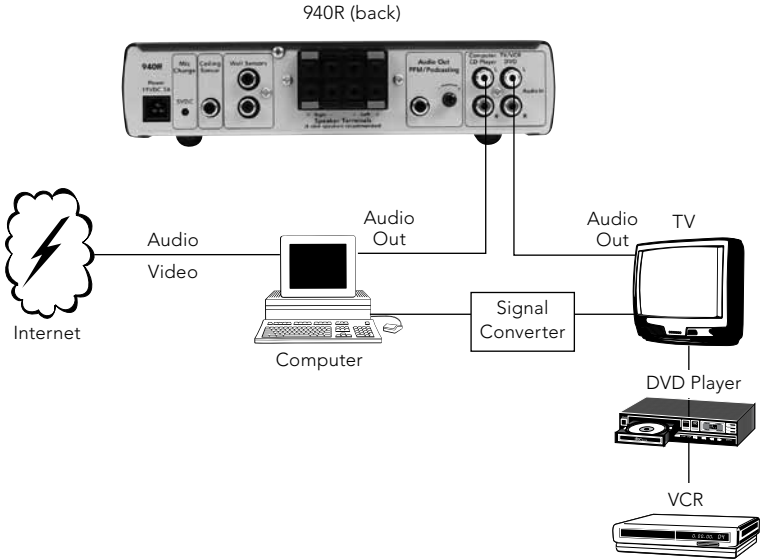

# 14 940R Pro Digital Receiver

## Auxiliary Output - Rebroadcasting to Personal FM Receivers



Allows rebroadcast of all voice and auxiliary audio directly to a hearing-impaired student's personal FM system.

1. Plug RCA cord into audio out port on back of Pro Digital receiver. Depending on the device you are connecting, match the type of the other end of the cord to the aux in on the transmitter (typically 3.5mm).
2. Adjust **volume level setting for transmitter**
  - a. if device you are connecting is a line level input, set volume control nearer to maximum
  - b. if device you are connecting is a mic level input, set volume control nearer to minimumTest and adjust as volume level as needed.

# 15 Troubleshooting

## **Receiver won't turn on (power light doesn't turn on)**

- Verify that the power supply is plugged into both the receiver and a working wall outlet
- Test with another power supply

## **Receiver keeps going into standby mode when playing auxiliary audio**

- Volume level on auxiliary audio device is set too low

## **Receiver will not "wake up" from standby mode**

- Volume level on auxiliary audio device is set too low
- Make sure microphone is on and working correctly, and the receiver is receiving the signal

## **Adapto LED keeps flashing on and off**

- This is normal. The light will turn on when the Adapto platform is processing the speech signal. There is nothing you need to do

## **'Dead spots' or microphone crackling/noise**

- Verify that you are not blocking either the emitters on the microphone or the sensors on receiver or mounted around room
- If reception is interrupted or noisy when facing a certain direction, install an additional sensor in that area of the room (see *Installer Guide*)
- If using more than one microphone, verify that they are not on the same channel
- Recharge or replace the microphone batteries

## **No signal reception (channel indicator light on receiver is red)**

- Check that the microphone is on
- Check that the microphone is not muted (940TM only)
- Verify that you are not blocking either the emitters on the microphone or the sensors on receiver or mounted around the room
- If reception is interrupted when facing a certain direction, install an additional sensor in that area of the room (see *Installer Guide*)
- If using more than one microphone, verify that they are not on the same channel
- Recharge or replace the microphone batteries

## **Feedback (squealing)**

- Lower the Microphone A or B Volume control(s) on the receiver
- Make sure that speakers are mounted as close as possible to the ceiling and to the listening area; avoid mounting speakers in the teacher's primary lecture area
- Position the microphone closer to mouth
- Select the Low or Medium OptiVoice setting
- Set the gain switch on the pass-around microphone to "mid" or "low"

## **Weak or no output from speaker(s)**

- Increase the Microphone A or B Volume or Aux-In Audio Volume control(s) on the receiver, or audio device
- Position the microphone closer to mouth
- Set the gain switch on the pass-around microphone to "mid" or "high"
- Verify that the speakers have been properly installed

## **High or low pitched whine or hum coming through speakers**

- There may be a ground loop with the system. Install a ground loop isolator (see *Installer Guide*)
- There may be "noisy" electrical wiring. Install an AC line filter (see *Installer Guide*)

## **Sensor lights are blinking**

- This is normal. When the 940R is in standby mode the sensor LED's will blink every two seconds

## **Charger light won't come on or is blinking red**

- Check that the charger is connected to a working power outlet
- The charger can charge only 950H and 940TM microphones with charge contacts. Refer to page 3, feature 12 to confirm that your microphone has these contacts.
- You may be attempting to charge an alkaline battery or a rechargeable battery that has reached the end of its useful life. Check the battery and replace with a FrontRow "silver sleeve" rechargeable battery.

# 16 Regulatory

## receiver: part 15, subpart B

FrontRow Pro Digital Receiver 940R  
FrontRow Pro Digital Transmitter 940TM



Tested to comply with  
FCC Standards

FOR HOME OR OFFICE USE

This equipment has been tested and found to comply with the limits for a Class B digital device, pursuant to Part 15 of the FCC Rules. These limits are designed to provide reasonable protection against harmful interference in a residential installation. This equipment generates, uses and can radiate radio frequency energy and, if not installed and used in accordance with the instructions, may cause harmful interference to radio communications. However, there is no guarantee that interference will not occur in a particular installation.

### FCC notes

The FrontRow Pro Digital active learning system is approved by the FCC (Federal Communications Commission). The use of the system may be governed by specific FCC rules and FCC licensing or notifications may be required. Consult your local FCC office for detailed information.

Phonic Ear receivers and transmitters, when required, are approved by the Federal Communications Commission (FCC) in the U.S. and Industry Canada. Other government approvals are available upon request. (Other international regulations may also apply.)

Any changes or modifications made to any government-approved element of this instrument, without the express approval of Phonic Ear, Inc. in writing, could void the user's authority to operate those elements of the system.

This product conforms with the essential requirements of European Union Directive /EU Directive 2004/108/EC EMC Directive and 2002/95 ROHS Directive. This product can be subject to interference at our operational frequency bands of 2.3 and 2.8 MHz.

This product has been cleared by the U.S. Food and Drug Administration for use by persons with normal hearing and hearing impairment.



*Electrical and electronic equipment (EEE) contains materials, components and substances, that could be dangerous or detrimental to human health and the environment if waste electrical and electronic equipment (WEEE) is not disposed of correctly. Products marked with the crossed-out dustbin shown here are electrical and electronic equipment. The crossed-out dustbin indicates that waste electrical and electronic equipment may not be disposed of with unsorted household waste and that it must be collected separately.*

*In developing and manufacturing your Phonic Ear product, we used high-quality materials and components that can be reused. Thus, when disposing of your waste electrical and electronic equipment, you must use a collection system designated for this purpose, regardless of whether you dispose of your waste at your local waste site or it is collected from your home. Please contact your local authority for further information.*

### IC notes

This Class B digital apparatus complies with Canadian ICES-003.

Cet appareil numérique de la classe B est conforme à la norme NMB-003 du Canada.

The term "IC:" before the radio certification number only signifies that Industry of Canada technical specifications were met.

# frontrow™

## **USA/Global**

FrontRow  
Corporate Headquarters  
2080 Lakeville Highway  
Petaluma, CA 94954-6713  
toll-free: 800.227.0735  
tel: 707.769.1110  
fax: 707.769.9624  
web: [www.gofrontrow.com](http://www.gofrontrow.com)

## **Australia**

Phonic Ear  
12/97 Castlemaine Street  
Milton Qld 4064  
Australia  
freecall: 1 800 PHONIC  
fax: 1300 746 642  
web: [www.gofrontrow.com.au](http://www.gofrontrow.com.au)

## **Canada**

FrontRow  
6950 Creditview Road, Unit 1  
Mississauga, ON L5N 0A6  
toll-free: 800.340.9894  
tel: 905.461.5300  
fax: 905.677.7760  
web: [www.gofrontrow.com](http://www.gofrontrow.com)

## **Scandinavia**

Phonic Ear A/S  
Kongebakken 9  
2765 Smørum  
Denmark  
tel: +45 3917 7101  
fax: +45 3927 7900  
web: [www.gofrontrow.com](http://www.gofrontrow.com)  
[www.phonicear.com](http://www.phonicear.com)

## **New Zealand**

Oticon New Zealand Ltd.  
142 Lambton Quay  
P.O. Box 9128  
Te Aro, Wellington  
toll-free: 800 OTICON  
toll-free fax: 00800 FAX  
OTICON  
web: [www.oticon.co.nz](http://www.oticon.co.nz)

## **United Kingdom**

PC Werth Limited  
Audiology House  
45 Nightingale Lane  
London SW12 8SP  
tel: 020 8772 2700  
web: [www.soundfield.info](http://www.soundfield.info)