

frontrow™  
pro digital



**INSTALLER GUIDE**

# YOU'RE ABOUT TO MAKE LEARNING MORE FUN

Welcome to FRONTROW -- the teacher-friendly way to improve the learning environment in every classroom. With your new active learning system, you'll enjoy greater student attention, less teacher fatigue, and very likely better test scores.

To help you start benefiting from your FRONTROW PRO DIGITAL system right away, we recommend that you first read the section in this guide called Before You Begin, and from there proceed to Steps 1 through 10. Be sure to consult the system user guide as well.

If you follow the steps set out in this Installer Guide and organize everything you need beforehand, you'll find setting up your FRONTROW PRO DIGITAL system to be quite simple. Of course, if you run into any obstacles, you can always call us at the number below. Our technical support representatives are happy to help.

Thank you for choosing FRONTROW!

## **USA/Global**

FrontRow  
Corporate Headquarters  
2080 Lakeville Highway  
Petaluma, CA 94954-6713  
toll-free: 800.227.0735  
tel: 707.769.1110  
fax: 707.769.9624  
web: [www.gofrontrow.com](http://www.gofrontrow.com)

## **Australia**

Phonic Ear  
12/97 Castlemaine Street  
Milton Qld 4064  
Australia  
freecall: 1 800 PHONIC  
fax: 1300 746 642  
web: [www.gofrontrow.com.au](http://www.gofrontrow.com.au)

## **Canada**

FrontRow  
6950 Creditview Road, Unit 1  
Mississauga, ON L5N 0A6  
toll-free: 800.340.9894  
tel: 905.461.5300  
fax: 905.677.7760  
web: [www.gofrontrow.com](http://www.gofrontrow.com)

## **Scandinavia**

Phonic Ear A/S  
Kongebakken 9  
2765 Smørum  
Denmark  
tel: +45 3917 7101  
fax: +45 3927 7900  
web: [www.gofrontrow.com](http://www.gofrontrow.com)  
[www.phonicear.com](http://www.phonicear.com)

## **New Zealand**

Oticon New Zealand Ltd.  
142 Lambton Quay  
P.O. Box 9128  
Te Aro, Wellington  
toll-free: 800 OTICON  
toll-free fax: 00800 FAX OTICON  
web: [www.oticon.co.nz](http://www.oticon.co.nz)

## **United Kingdom**

PC Werth Limited  
Audiology House  
45 Nightingale Lane  
London SW12 8SP  
tel: 020 8772 2700  
web: [www.soundfield.info](http://www.soundfield.info)

# CONTENTS

Step 1..... Pages 1-5  
Before you begin

Step 2.....Page 6  
Get yourself ready

Step 3..... Pages 7-10  
Plan your installation (Speakers)

Step 4..... Pages 11-14  
Plan your installation (Sensors)

Step 5..... Pages 15-16  
Install the receiver

Step 6..... Pages 17-18  
Connect media

Step 7..... Pages 19-24  
Install speakers

Step 8..... Pages 25-26  
Install sensors

Step 9..... Pages 27  
Test system

Appendix A..... Pages 28  
Pro Digital Teacher's Tips

Appendix B..... Pages 29  
Special speaker connections

Appendix C..... Pages 30-31  
Troubleshooting

## Read

Be sure to read the helpful tip boxes found throughout this guide. Of course, if you need further assistance, you can always call us at one of the numbers found on the previous page.

# Step 1: Before you begin

Make sure you've got everything you need to set up your FRONTROW PRO DIGITAL active learning system. By taking a few minutes to prepare, you'll help ensure the actual set-up is as quick and problem-free as possible.

## Visualize your goal

When your FrontRow Pro Digital system is installed, it will look something like this:

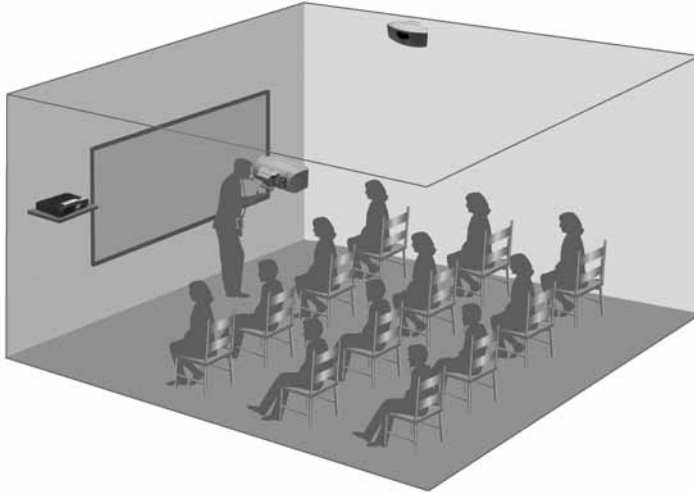

## General safety precautions

- Do not install or use the receiver near water or heat sources
- Clean only with a dry cloth
- Do not block any ventilation openings
- Protect all cables from wear and damage from foot traffic, doors, and other hazards
- Use only accessories specified by FrontRow
- Refer servicing to qualified service personnel
- Wear safety goggles when using power tools
- Follow all safety guidelines when using ladders
- Observe your local building, electrical, and fire codes when installing any electrical equipment
- Use at least 18-gauge plenum speaker wire (included with system)

# Get your classroom ready

## 1. Does your classroom meet the system requirements?

Check the table below to confirm that your classroom is set up properly for the FRONTROW PRO DIGITAL system you have. In most cases one ceiling sensor will be sufficient. However, some classrooms may require one or more additional sensors for optimal room coverage. While other classroom configurations may work with your FRONTROW PRO DIGITAL system, we can only support those listed below.

Size	<input type="radio"/> < 900ft <sup>2</sup>	<input type="radio"/> 900ft <sup>2</sup> - 1500ft <sup>2</sup>
Walls	<input type="radio"/> Light colors	<input type="radio"/> Dark colors
Windows	<input type="radio"/> Few	<input type="radio"/> Many (>50% window-to-wall area)
Obstructions (hanging art, tall free-standing bookshelves, suspended lights)	<input type="radio"/> Few	<input type="radio"/> Many
Shape	<input type="radio"/> Simple (Square, Rectangle)	<input type="radio"/> Complex (Alcoves/bays where teachers may walk)

$$\frac{\text{Total Checked}}{\quad} \times 1 \quad + \quad \frac{\text{Total Checked}}{\quad} \times 3 \quad = \quad \boxed{\quad}$$

<b>If your score is:</b>	<b>We recommend:</b>
< = 5	1 ceiling sensor
6 - 10	1 ceiling sensor + 1 wall* sensor <b>OR</b> 2 ceiling sensors
11+	3 sensors (any combination of wall* or ceiling)

\*Wall sensors can help where there are ceiling obstructions (hanging lights, artwork, etc.)

## 2. Think about combining your other teaching technologies

Your FRONTROW PRO DIGITAL system is the communication center of your classroom. Take advantage of this opportunity to connect your TV, VCR, computer, CD player, MP3 player and other teaching technology to your active learning system. This will allow children to hear not only your voice, but also the rich multimedia content you're providing, regardless of where they're seated.

Deciding what other devices you'll want to connect to your FrontRow Pro Digital system now will make positioning the receiver easier in Step 1. There are four ways to approach integration.

### Example 1

Many classrooms use a computer as a multi-media "hub" (with an LCD projector), which is connected to the internet or school network to download/stream all audio and video, and MP3 files. For these classrooms, you may only require one auxiliary audio input connection to the 940R.

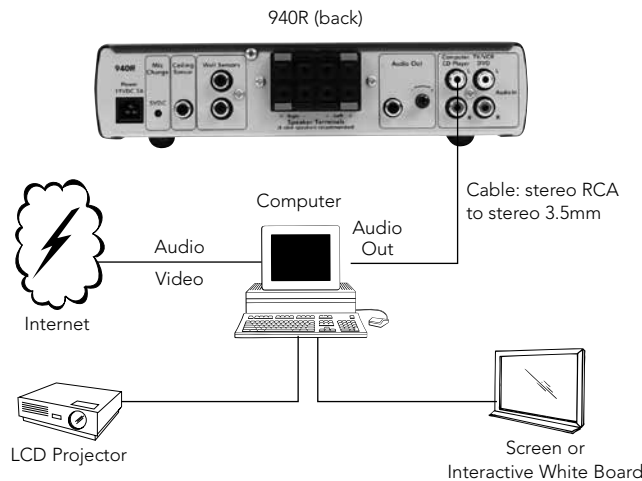

## Example 2

Some classrooms use a computer as the multi-media "hub", but it is connected to a TV instead of an LCD projector. They also occasionally use the TV/DVD/VCR as a stand alone media. For these classrooms, you may need to use both auxiliary audio input connections to the 940R.

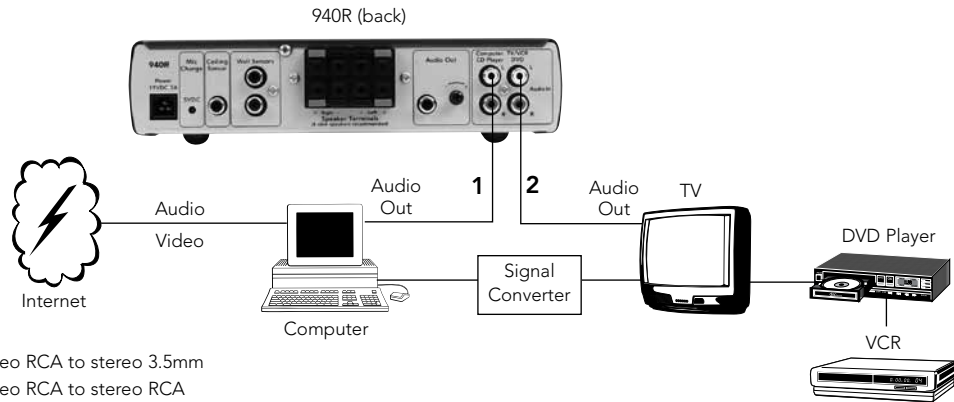

- 1 Cable: stereo RCA to stereo 3.5mm
- 2 Cable: stereo RCA to stereo RCA

## Example 3\*

Some classrooms may have many different types of media, but because of the age of the equipment or incompatible input/outputs, they may not integrate with each other. For these classrooms, you may choose to use an auxiliary audio box to connect all the sources to one location, then connect it to one audio input connection to the 940R.

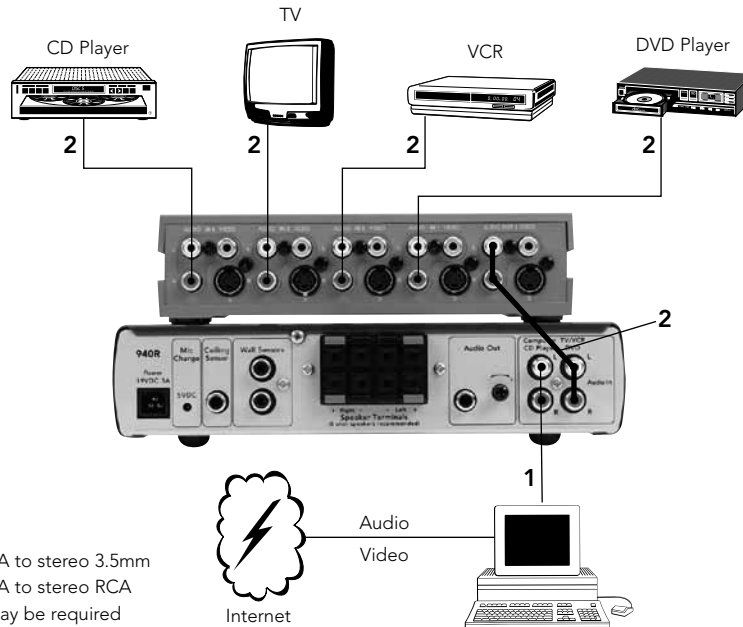

- 1 Cable: stereo RCA to stereo 3.5mm
  - 2 Cable: stereo RCA to stereo RCA
- \*Additional cords may be required

## Example 4

This is less work for the installer, but slightly more involved for the teacher.

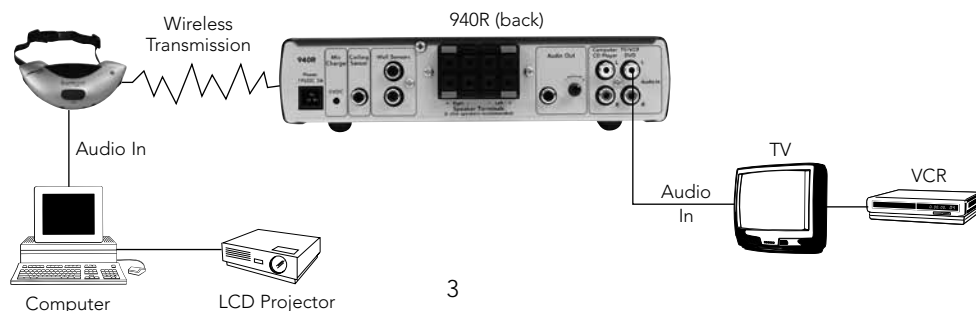

# Get your FrontRow Pro Digital parts ready

Check the contents of your FrontRow Pro Digital installation kit against the parts listed below. To help you stay organized, we recommend that you keep the parts needed for each step separate.

## 1. Open your main component box

### 940 System Box



202-00-410-00 (US/CAN)  
202-00-411-00 (AUS/NZ)  
202-00-412-00 (EU)  
202-00-413-00 (UK)

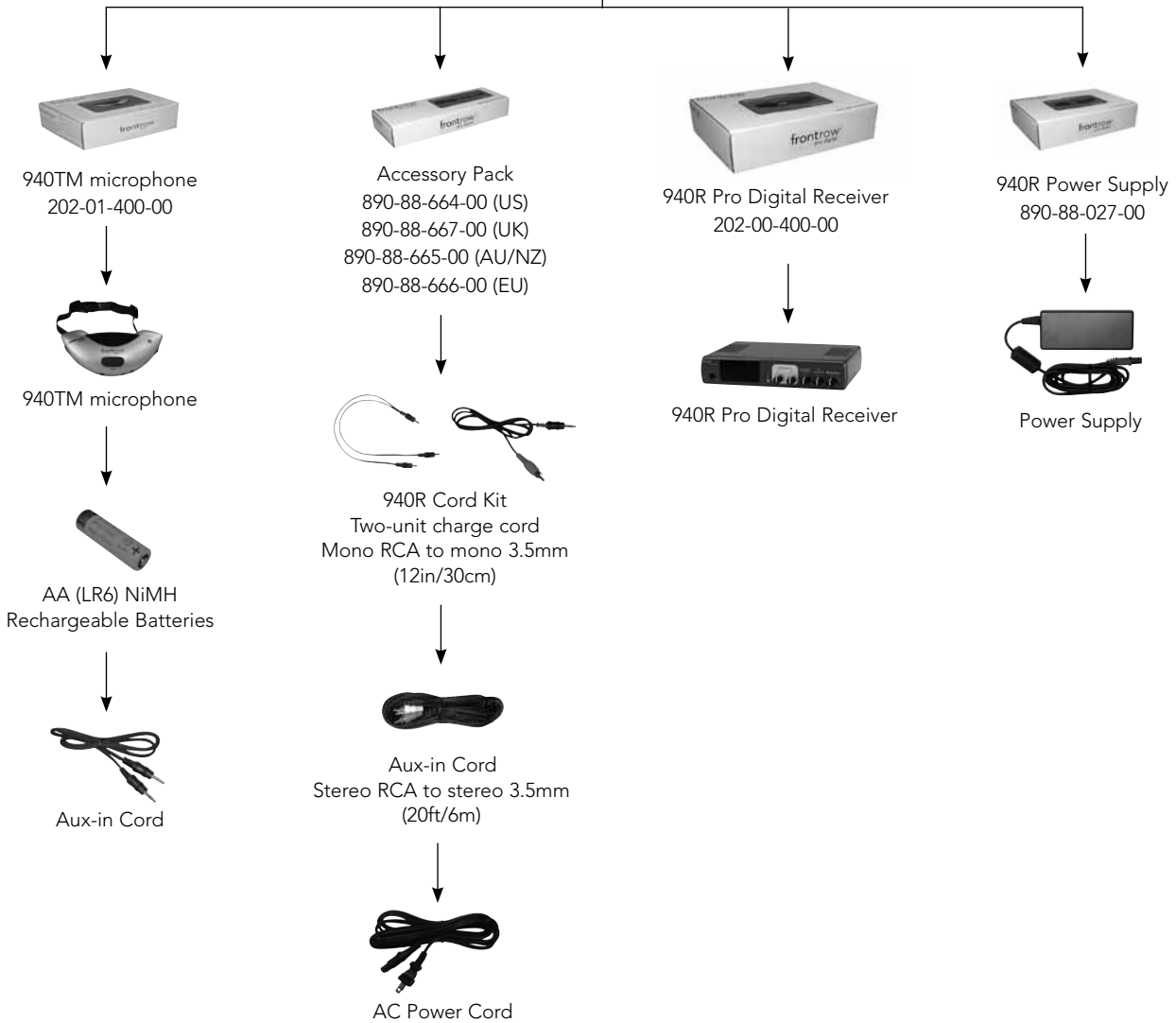

## 2. Open your sensor box

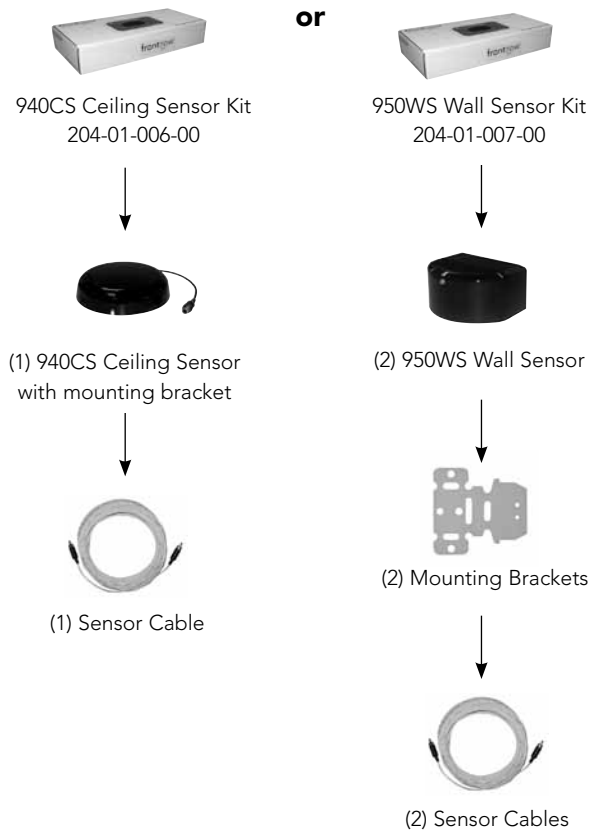

## 3. Open other optional boxes

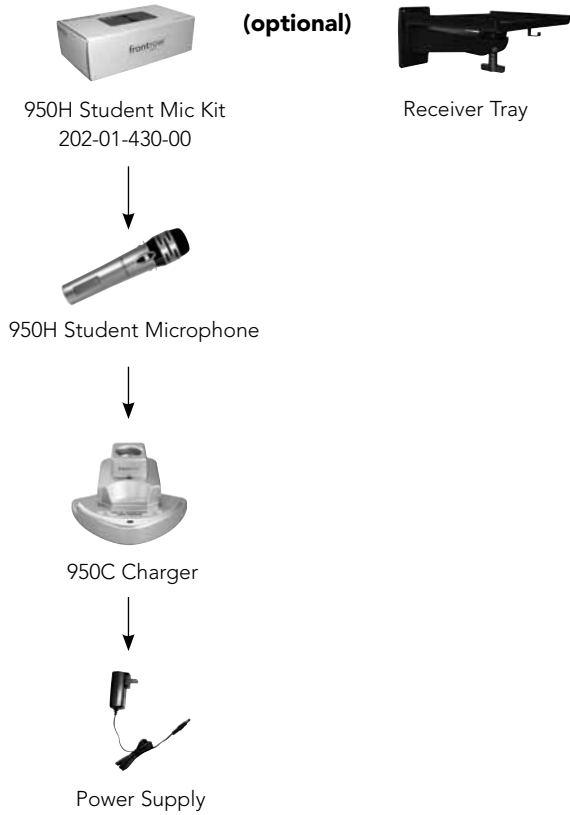

## 4. Open your speaker box

This box should contain:

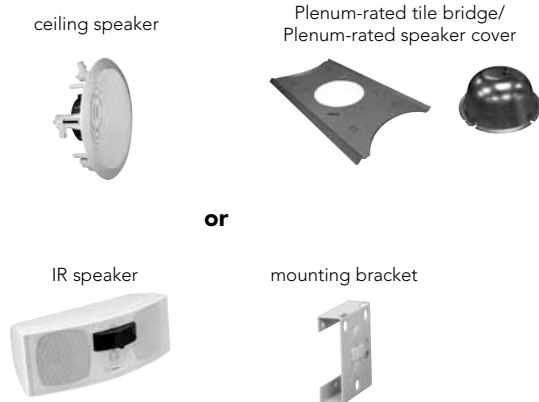

# Step 2: Get yourself ready

Nearly everything you need to install your FrontRow Pro Digital system is included in the boxes we shipped. You will need some basic tools and materials, depending on how your classroom is built:

## 1. What kind of walls do you have?

For drywall installations (similar to most houses) gather the following tools:

Drill	Wall anchors
Drill bits	Cable tacks/staples
Phillips #2 driver bit	Plastic cable (zip) ties
Level or ruler/tape measure	Plastic raceway with screws
Crimp pliers or scissors	Tin snips (optional)
Hammer	Ladder
Staple gun	Safety goggles

For concrete walls, assemble the following tools:

Hammer drill	Hammer
Masonry drill bits	Plastic cable (zip) ties
Phillips #2 driver bit	Plastic raceway with adhesive
Level or ruler/tape measure	Tin snips (optional)
Crimp pliers or scissors	Ladder
Concrete screws	Safety goggles

## 2. Are you installing ceiling speakers?

If so, you'll also need:

Keyhole saw or sabre saw or RotoZip

Electrical tape

Short length of string or twine

# Step 3: Plan your installation (Speakers)

**Estimated time for this step: 5-10 minutes**

Your classroom is ready and you've organized all the parts and tools you'll need to set up your active learning system. Now it's time to decide where you'll place major components. To help you decide, we'll use the following layout of a typical classroom as an example:

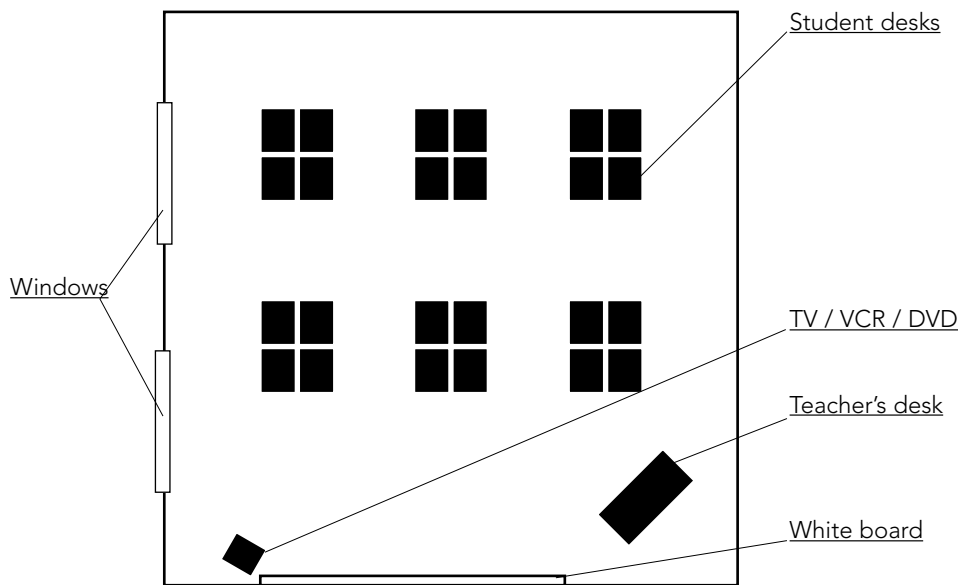

Top view of an example classroom

## 1. Decide where to put the receiver

We recommend locating the receiver in a corner with good visibility of the classroom, at about the teacher's eye-level.

If you're going to be connecting other audio sources to your receiver (see Before You Begin), consider a location near the teacher's computer or TV/VCR/DVD. There are probably convenient power sources near these as well.

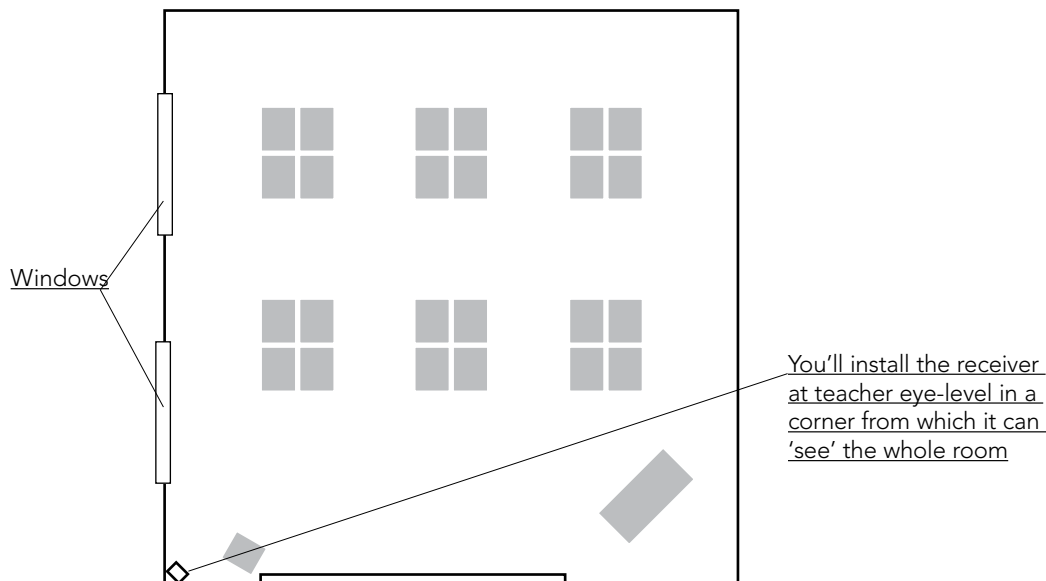

A good place for the receiver

## 2. Plan speaker placement

Proper speaker placement is critical to getting optimum benefit from any active learning system. Improperly chosen or installed speakers can actually harm intelligibility, so please take the time to plan this step thoroughly.

It's useful to imagine each speaker as a flashlight, and that your goal is to light up the areas where students are sitting. Speakers should therefore be focused on the students and facing them.

Speaker symbols:

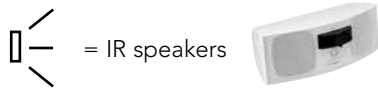
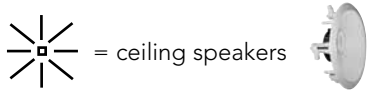

## a Installing ceiling speakers?

Use the following guidelines when choosing where to put your ceiling speakers:

Define the area where students are sitting -- this is the area you want to cover with speakers; not the entire room.

Divide this area into four equal sections.

Using a piece of tape, mark a ceiling tile in the center of each of the four sections -- these are the tiles where you'll mount your ceiling speakers.

Avoid installing speakers directly in front of the white board -- this not only covers an area not used by students but increases the chance of feedback.

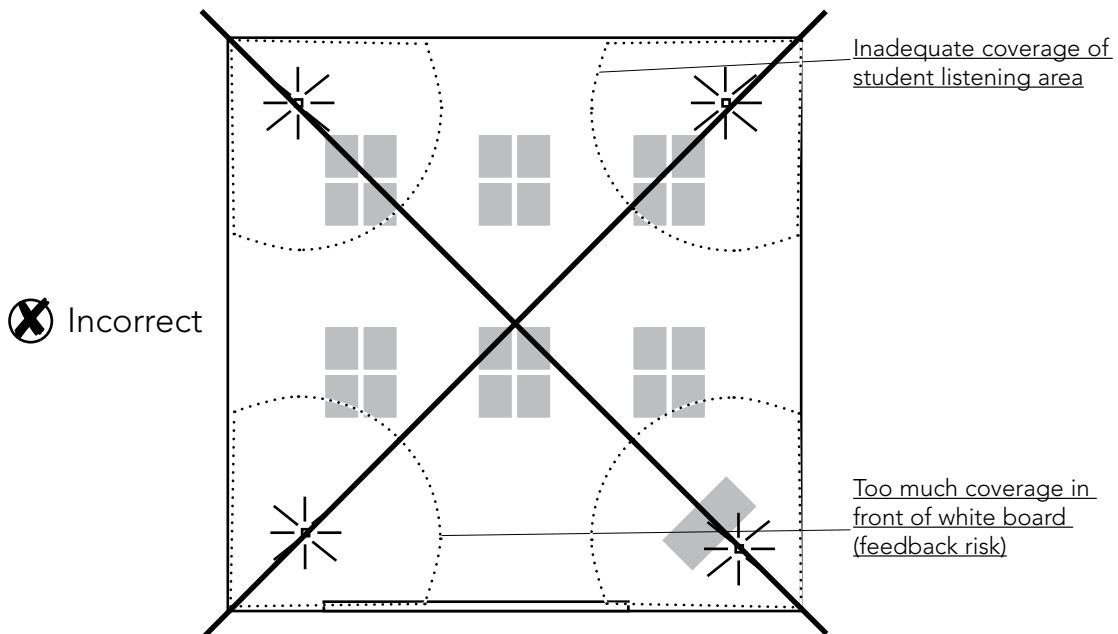
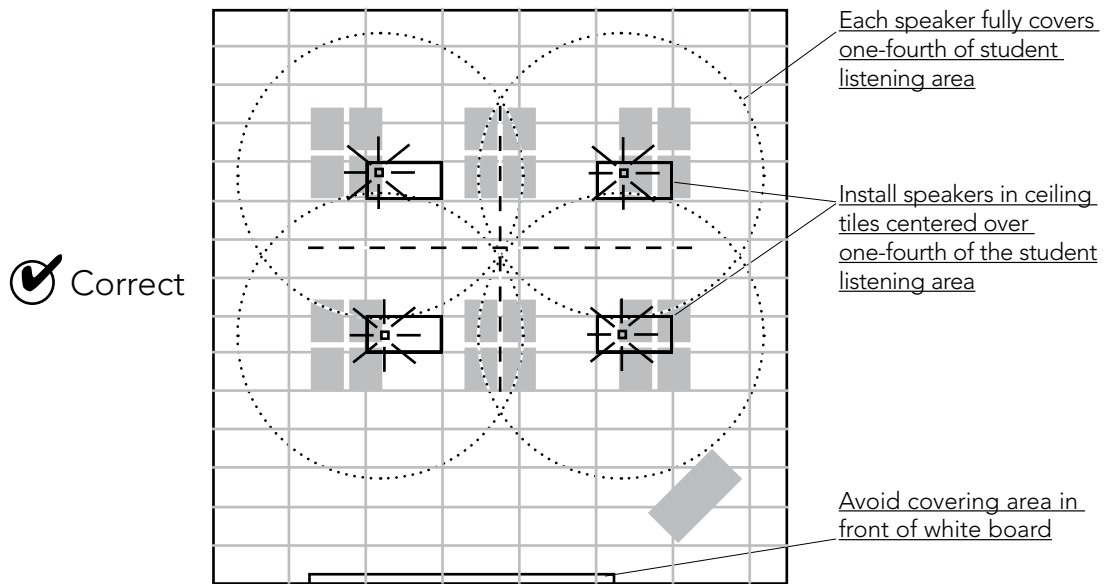

## b Installing IR speakers?

Use the following guidelines when choosing where to put your IR-Speakers:

- Define the area where students are sitting — this is the area you want to cover with speakers; not the entire room.
- Mentally divide this area into two equal sections running parallel to the whiteboard/main lecture area.
- Using a piece of tape, mark a desk in the center of each of the sections — these are the targets at which you'll aim each of your IR-Speakers.
- Speakers should only be placed on the side walls of the classroom.
- Walls should have a space approximately 10in wide by 5in tall (25 x 13cm) to solidly mount the wall bracket.
- If the room has drop lighting, the speaker should be placed just below the bottom of the lights — the teacher should be able to see at least one speaker from all parts of the room.
- Avoid installing speakers directly in front of the white board — this not only covers an area not used by students – but increases the chance of feedback.

 Correct

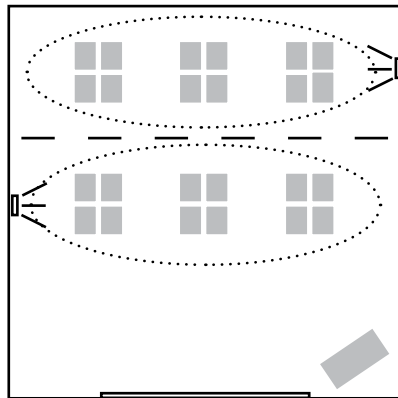

Avoid covering area in front of whiteboard

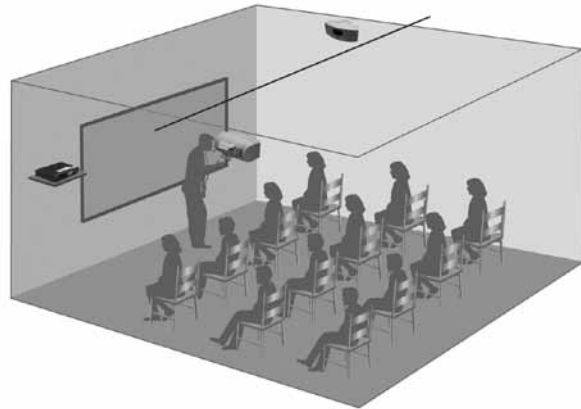

 Incorrect

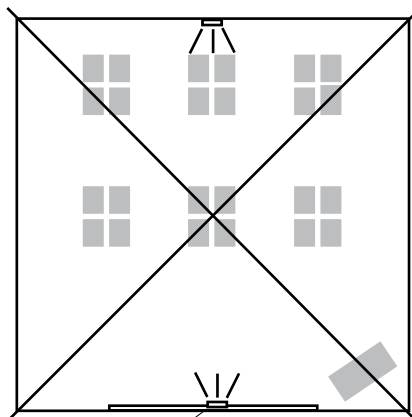

Too much coverage in front of whiteboard (feedback risk)

# Step 4: Plan your installation (Sensors)

## (If you are using IR-Speakers, skip to section 7)

### SENSOR & SENSOR CABLE

The sensor and sensor cable are critical elements in the system and the most sensitive to electrical noise.

- DO NOT** shorten OR lengthen the sensor cable. Its factory-specified length is critical to the performance of the system.
- DO NOT** use a splitter with the sensor cable.
- DO NOT** use a different cable.
- DO NOT** alter the RCA connectors on the cable.
- AVOID** routing the sensor cable next to other cables or electrical systems (e.g., other electrical conduit, Ethernet cable, video cable, fluorescent light ballast, etc.). Leave at least 6 in. (15cm) space around the sensor cable.
- The sensor cable is UL listed. Excess cable can be coiled, tied and placed safely in a plenum space. **DO NOT** place the sensor coil near other cables or electrical systems (e.g., other electrical conduit, Ethernet cable, video cable, fluorescent light ballast, etc.).
- Route the sensor cable **AWAY** from the speaker wires as far as practical. We recommend leaving at least 6 in. (15cm) between the two whenever possible.

### Interference and IR Coverage

The FrontRow Pro Digital system uses infrared light to transmit the voice signal from the microphone to the sensor in the ceiling/wall sensors. Proper placement of the sensors is critical for optimal system performance.

- Adjacent classrooms that use FrontRow infrared systems can interfere with each other if the rooms are separated by windows. The windows allow the infrared light to "escape" from the classroom only to be picked up by the sensors in the adjacent classroom, causing interference and "cross talk". Be sure to recommend window coverings to the greatest extent practical when using the system.
- Direct sunlight can reduce system performance. Be sure to recommend window coverings to the greatest extent practical when using the system.
- Infrared light has better reflection off of white and glossy surfaces. The ceiling sensor can be placed to help provide coverage in areas where the signal may be weak due to insufficient infrared reflection.

Your FrontRow Pro Digital receiver has a powerful built-in sensor -- often sufficient to serve your entire classroom. The walls or design of some classrooms may not allow for the direct transmission and reflections of infrared light that your active learning system relies on. That's why it's a good idea to plan for external sensors.

Sensor symbols:



Possible external sensor combinations:

sensor combinations	maximum connections
ceiling sensor only	2*
wall sensor(s) only	3
ceiling & wall sensor	1 ceiling sensor, 2 wall sensors

\*1 ceiling sensor can be connected to the wall sensor port.

## 1. Positioning a ceiling sensor

A ceiling sensor is designed to 'see' the entire room at once, and so can often fill in any gaps in reception by the main receiver. Use the following guidelines when installing a ceiling sensor:

Mentally divide the room in half, with the main receiver contained within one half.

Use a piece of tape to mark a spot on the ceiling that is centered within the other half of the room -- This is where you will install the ceiling sensor.

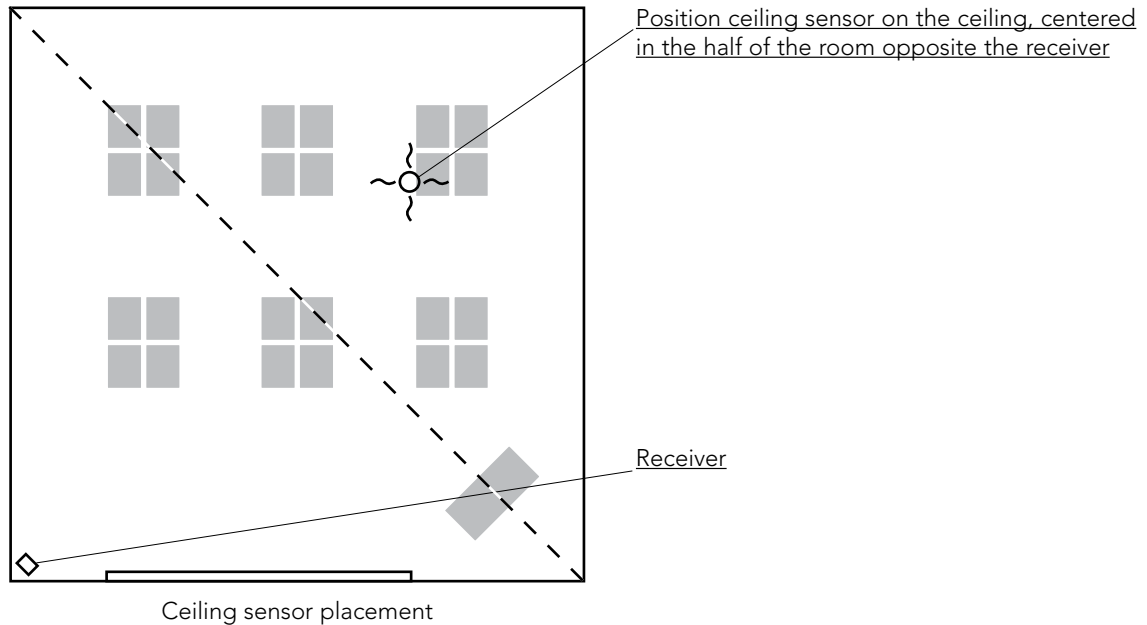

Assessing the individual characteristics of the environment is critical to achieving the best performance. Poor coverage planning can dramatically reduce the performance of the system.

- DO NOT** mount the ceiling sensor or wall sensors in direct sunlight as it will greatly reduce performance.
- The ceiling sensor must have a clear view of the coverage area and must be mounted parallel to the floor to function optimally (figure 1). If drop lights are used in the room, wall sensors may be a better option. Or, a drop mount\* may be used to lower the ceiling sensor.

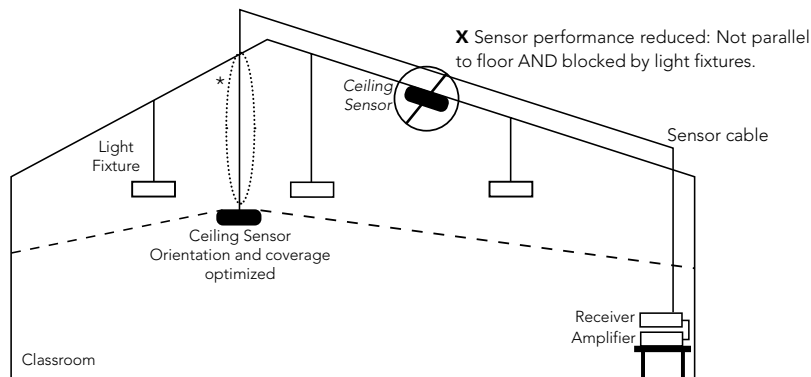

Figure 1: Ceiling Sensor Installation

\*not supplied by FrontRow

## 2. Positioning 2 wall sensors

Wall sensors are ideal for complete coverage of rooms, even those with non-reflective or obstructing walls. Use the following guidelines when installing wall sensors:

Mentally divide the room into three equal sections, with the main receiver contained within one section.

Use a piece of tape to mark a spot for each of the two wall sensors. The spot you choose should be:

- On the wall, as close to the ceiling as possible.
- In a position such that the teacher can see at least one sensor from all parts of the room.

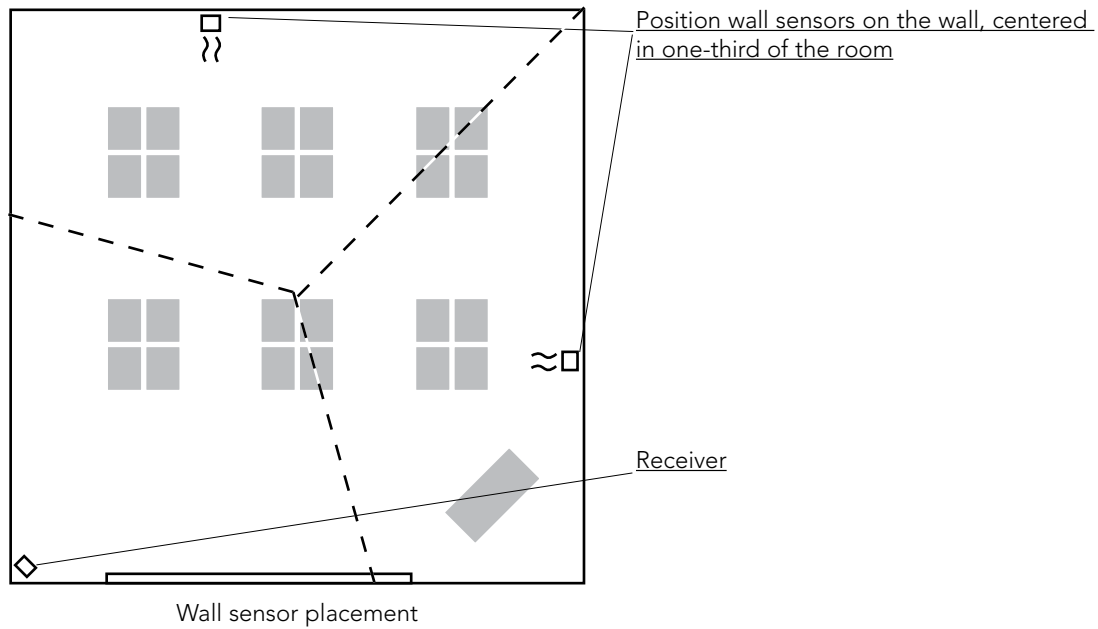

### 3. Positioning ceiling and wall sensors

Combining external sensors is ideal for complete coverage of odd sized or oversized rooms with or without non-reflecting or obstructing walls. Use the following guidelines when installing ceiling and wall sensors:

- Mentally divide an odd-shaped room into sections as shown. The receiver and ceiling sensor should cover the larger sections of the room and the wall sensor should cover the alcove or smaller section.
- For larger sized rooms greater than 2500 sq. ft./225m<sup>2</sup> we recommend using external wall sensors only (up to 3 wall sensors maximum) for optimum room coverage in IR challenging room environments.
- Use a piece of tape to mark a spot on the ceiling that is centered within one half of the large section of the room – this is where you will install the ceiling sensor.
- Use a piece of tape to mark a spot for each of the wall sensors. The spot you choose should be:
  - on a wall, as close to the ceiling as possible.
  - in a position such that the teacher can see at least one sensor from all parts of the room.

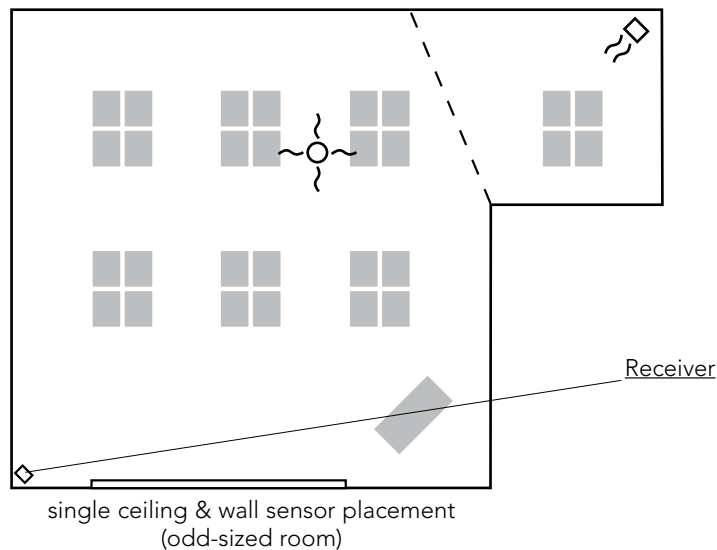

or

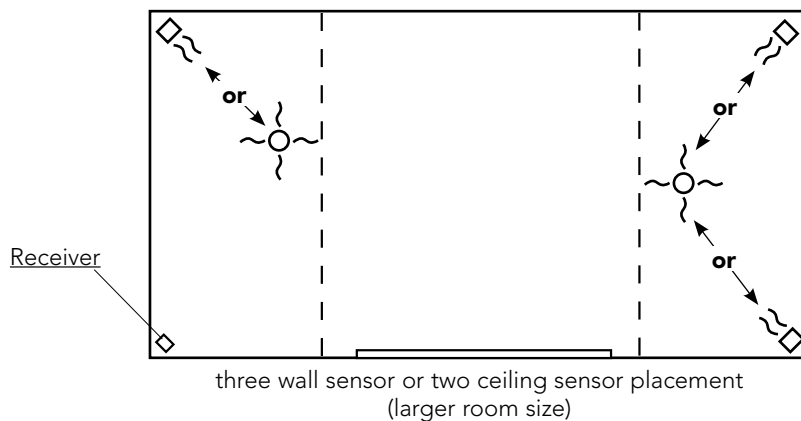

# Step 5: Install the receiver

## **Estimated time for this step: 15 minutes**

The receiver has a built in sensor that works like the ceiling or wall sensors. To maximize the reception of the internal sensor, it must be mounted so it can “see” as much of the room as possible.

- a. Place the receiver at the instructor's eye level (approximately 5-6 ft. [1.5-2m] from the floor). The receiver may be placed on a shelf, however we recommend using the FrontRow receiver tray.
- b. If mounted less than 5 ft. (1.5m) from the floor, the receiver should be mounted parallel to the floor. If mounted 6 ft. (2m) or higher from the floor, the receiver should be angled downward slightly.
- c. Ensure the receiver is installed to comply with ADA standards.
- d. Secure the receiver tray to ensure it can't easily be rotated or angled into a less than optimal position.
- e. **DO NOT** place the receiver in direct sunlight as it will greatly reduce performance.
- f. **DO NOT** bundle the FrontRow power supply (or any power supply) along with the speaker or sensor cable.
- f. **DO NOT** bundle the FrontRow power supply (or any power supply) directly next to OR on top of the receiver.

With the positions of all your major components settled, you can now install your receiver.

1. Install optional receiver tray to wall at teacher eye-level according to installation instructions included with tray.
2. Place receiver on tray.
3. Slightly loosen tightening knob and angle main sensor toward center of room, and tighten knob.
4. Plug power supply into receiver.
5. Plug power supply into wall socket.
6. Connect any other teaching technology — TV / VCR / DVD, teacher's computer, etc. — to your FRONTROW PRO DIGITAL system through the Aux Input jacks (cables supplied).

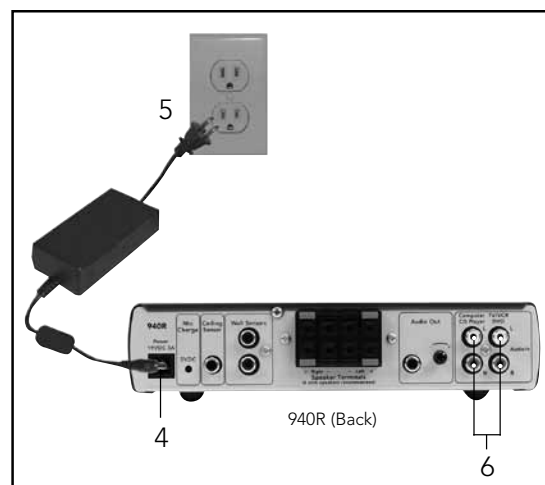
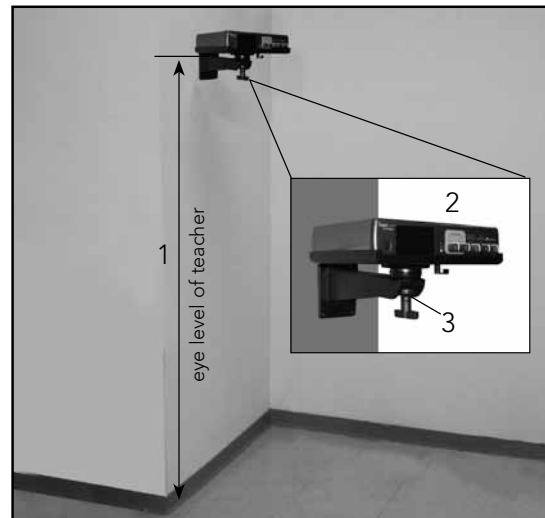

## Rackmounting

The FRONTROW PRO DIGITAL receiver may be placed in a rack using a standard shelf that accommodates the physical dimensions of the receiver. The FRONTROW PRO DIGITAL receiver will not accommodate “wings” or other rack accessories which attach directly to a unit. Airflow should not be restricted in the rack. The following guidelines must be considered when rack mounting the receiver:

- a. **Coverage.** The FrontRow Pro Digital receiver has an internal sensor that works like the external ceiling or wall sensor.



The internal sensor can be used alone or in tandem with external sensors. If the location of the receiver in the rack prevents the internal sensor from being fully exposed to the coverage area, the sensor should be disabled\*. The internal sensor cannot be disabled in the field. With reasonable notice FrontRow can disable the internal sensor prior to shipment.

When placing the receiver in the rack where exposure to the coverage area is possible, be sure to secure the receiver on the shelf to prevent it from sliding to the rear of the shelf or changing orientation.

- b. **Technical Support.** Contact FrontRow technical support at US: 800.227.0735, CAN: 800.340.9894 if you have any questions regarding installation or troubleshooting.

*\*Each sensor contributes a small degree of electrical noise in the system. A properly used sensor, one that is exposed to the coverage area, improves system performance far above the electrical noise that is introduced. Conversely, a sensor that is NOT exposed to the coverage area (e.g., receiver placed in a closed rack system), contributes a small degree of electrical noise in the system with no benefit in performance.*

### Tip

#### Point your receiver away from windows

Your FrontRow Pro Digital system communicates using infrared light. Strong sunlight can overwhelm that communication. Your receiver will perform best if it is pointed away from windows that get direct sunlight.

# Step 6: Connect cables

**Estimated time for this step: 45 minutes**

With your receiver installed, you now have a base for routing your cables.

## DROP-CEILING ROUTING

If you want to run cables above a drop (acoustic tile) ceiling, follow the guidelines below. (If you just run cables along the wall, follow the instructions starting on page 17.)

### 1. Remove selected ceiling tiles

Remove any ceiling tiles you marked in **Step 3**.

Remove the ceiling tiles directly above the sensor or IR speaker locations you marked in **Step 4**.

Remove the ceiling tile directly above the receiver you mounted in **Step 5**.

### 2. Prepare and route cable

Tie an object, such as a roll of electrical tape, to some twine to use as a pull line. This will help you more accurately direct the cable in the area above the ceiling.

Standing on a ladder with your head and shoulders in the space where you'll install a ceiling speaker, toss the weighted end of your twine through ceiling space into the open tile hole above your receiver.

Connect the other end of the twine to the speaker cable. Pull cable through to the receiver.

Your goal is to have the cable entirely above the ceiling, with only the two ends protruding from the open space above the receiver and your chosen speaker tile.

Repeat these steps for the other three speakers and for your sensors.

**Note: Do not shorten or lengthen the sensor cable. Doing so may reduce system performance.**



## Tip

### Can't get the pull line to the receiver in one throw?

Get the weighted end of the pull line as close to the receiver as you can. Then move your ladder under the tile where your cable stopped, remove that tile, and repeat until you've hit the mark.

### 3. Install raceway

You can neatly conceal all cables running between the receiver and the ceiling space using widely-available plastic raceway.

Cut enough raceway to extend from just behind your mounted receiver to the ceiling.

Using a level or tape measure to ensure straightness, attach the raceway to the wall.

Route all speaker and sensor cables in raceway and close.



### 4. Support cables

Ensure cables are installed in adherence to local and national electric codes. Speaker and sensor cables should not rest on the ceiling. Lift them off the ceiling and use cable/zip ties to secure them loosely to beams, anchor bolts, or other support structures in the ceiling (do not attach them to ductwork, plumbing, or other secondary work).

## WALL ROUTING

If you're routing cables along walls, follow these guidelines:

#### 1. Tack cable

Starting at one of your marked speaker locations, begin securing speaker cable to the wall with professional cable tacks. For a neat installation, try to keep the cable as close to the ceiling as possible. Leave about 20cm slack for your eventual connection to the speaker.

Make your way back toward the receiver.

Repeat for the other speakers and sensors in the room.

## CONNECT CABLES TO RECEIVER

To ensure faithful reproduction of stereo auxiliary inputs, be sure to properly match the red/black and left/right speaker wires to the proper receiver terminals.

Connect all speaker and sensor cables as shown:

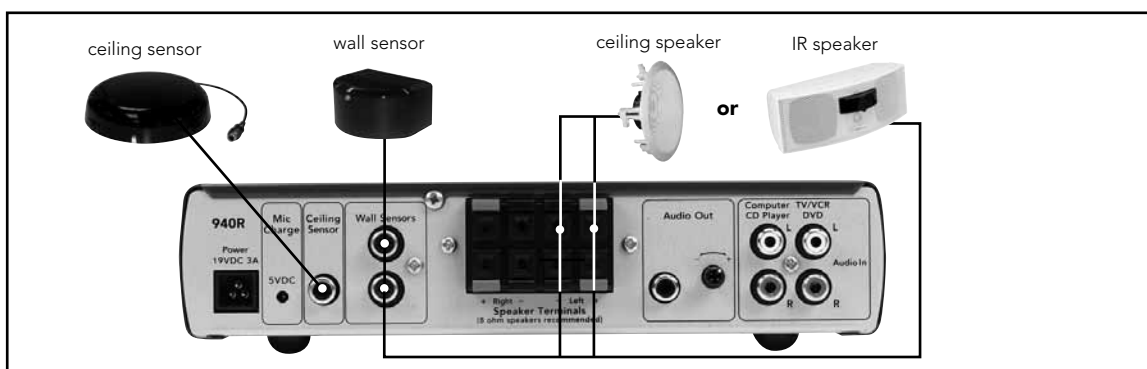

# Step 7: Install speakers

**Estimated time for this step: 30 minutes**

Now that your cables are in place, you're ready to install your speakers.

## 1. Plenum-rated ceiling speaker



If you're putting in ceiling speakers, do the following:

### a. Take down the ceiling tiles you marked in Step 3.

### b. Cut ceiling tiles

Lay each bridge on its tile so that the ends of the bridge are flush with both edges of the tile.

Use the bridge as a template to trace a circle on the ceiling tile.

Using a keyhole saw, cut the traced circle out of the tile.

Repeat for your other speaker tiles.



### c. Assemble speakers, bridges, and tiles

1. Remove the front grill from a speaker. Insert the back of the speaker up through the hole you've cut in the tile and then through the hole in the tile bridge. Be sure the finished side of the tile is facing downward (toward the front of the speaker) and that the ends of the tile bridge are flush with the edges of the tile.

2. Fold out the speaker support tabs.

3. Tighten the mounting screws to compress the tile bridge and tile between the mounting tabs and the speaker front. The speaker should be snug against the tile and bridge.

4. Feed speaker wire through opening at the top of the speaker back can.

5. Attach speaker wire to terminals. Be sure to match red wire to red terminal and black wire to black terminal.

6. Secure back can to tile bridge by folding clips into the four slots in the bridge.

7. Tighten wire clamp to secure speaker wire.

8. Reattach speaker front grill.

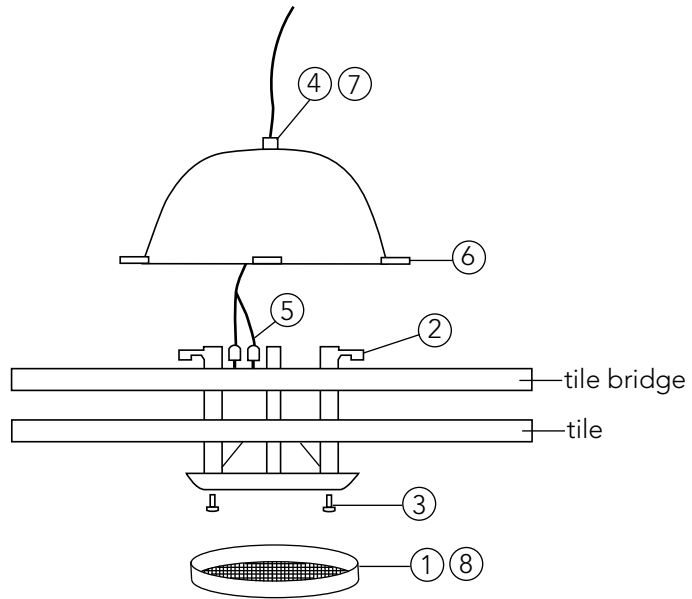

### d. Replace tiles

Drop the tile/speaker assembly back into position in the tile grid by tilting it slightly, lifting it above the framework, and letting it fall into place. Be certain that the two short sides of the metal tile bridge are resting on top of the T-bar rails holding the ceiling tiles in place, and that the speaker wire is free for routing in Step 8.

### e. Speaker wires

- MINIMIZE** speaker wiring and save time by daisy-chaining in parallel left and right speakers. Running individual speaker wire from each speaker to the terminal block on the receiver is not required.
- DO NOT** coil up the excess speaker wire. Excess speaker wire should be trimmed and used for other speakers, if possible.
- AVOID** bundling sensor cables and speaker wires together (except for final run from ceiling to receiver unit). We recommend leaving at least 6 in. (15cm) between the two whenever possible.

## IR SPEAKERS

### IMPORTANT INFORMATION

1. Speakers should only be placed on the side walls of the classroom.
2. Walls should have a space approximately 10in wide by 5in tall (25 x 13cm) to solidly mount the wall bracket.
3. If the room has drop lighting, the speaker should be placed just below the bottom of the lights.
4. **DO NOT** shorten sensor cables.
5. **DO NOT** lengthen cables.
6. **DO NOT** use a splitter or adaptor with cables.

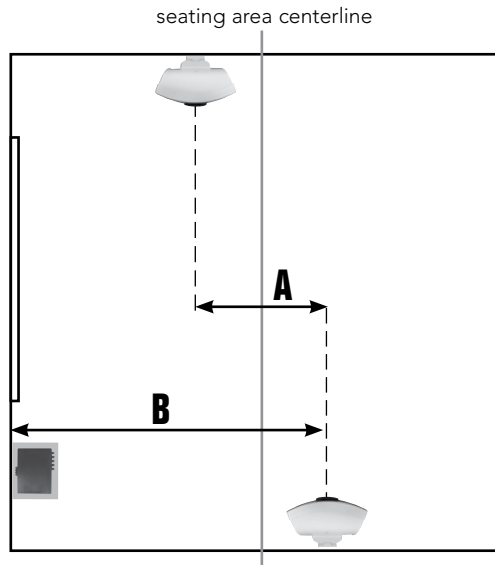

### INSTALLATION DIMENSIONS

- A** Speakers should be 3 to 6ft. (1 to 2m) apart, CENTER TO CENTER. **NOTE:** Do NOT place directly opposite each other.
- B** Speaker on same side of room as 940R should be farthest from receiver.
- C** Speakers should be mounted between 7.5 to 10ft (2.3 to 3m) from the floor.
- D** Speakers should be mounted at least 5in (13cm) from the ceiling.

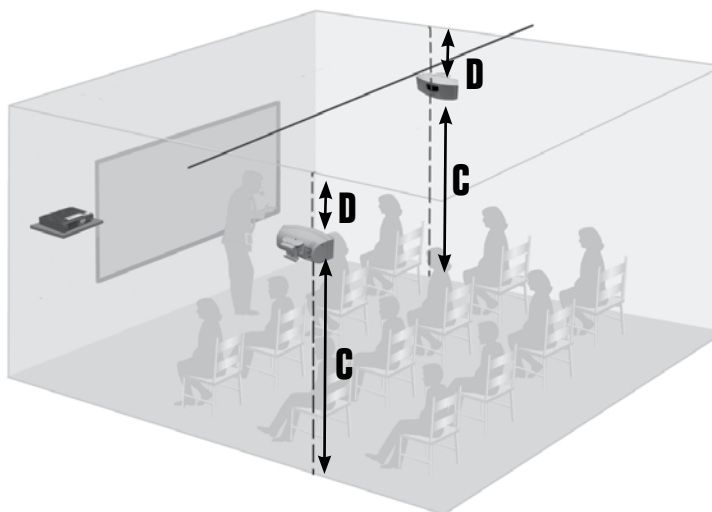

**We recommend the following hardware to mount your speakers:**

Drywall		
<b>YES</b>	<b>YES</b>	<b>YES</b>
Hollow Wall Anchor #6 x 2in min.	Hollow Wall Anchor #10 x 2in min.	Toggle Bolt Anchor #6 x 2in min.
<b>NO</b>	<b>NO</b>	<b>NO</b>
Plastic Shield Anchor	Threaded Wall Anchor	Hollow Wall Anchor #6 x 1.75in.

Concrete/Cinderblock/Brick	
<b>YES</b>	<b>NO</b>
Lead Shield Anchor #8 x 1.5in.	Plastic Shield Anchor

1. Mark drill holes using template from speaker box.
2. Mount wall plate  
**NOTE:** Use hardware appropriate for your wall type.
3. Attach cables to receiver  
**NOTE:** Remember to connect one speaker to the LEFT channel and one to the RIGHT channel.
4. Run cable to speaker locations  
**NOTE:** The cable is UL listed. If there is any excess cable, it can be safely stored in the plenum space. If there is no plenum space see instructions, "TRIMMING COMBO CABLE".
5. Angle speaker toward the center of the closest half of the classroom. Tighten knob.
6. Attach cables.
7. Attach speaker to wall plate and install set screw.

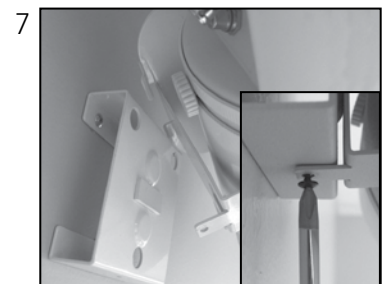
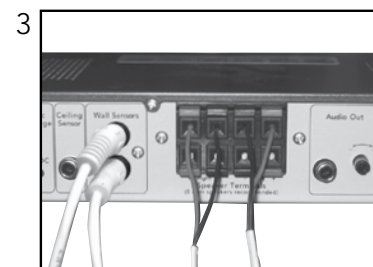
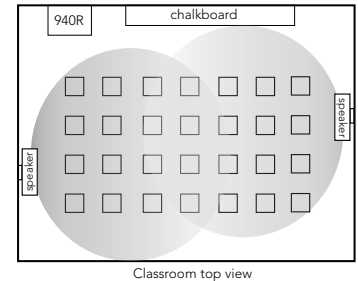
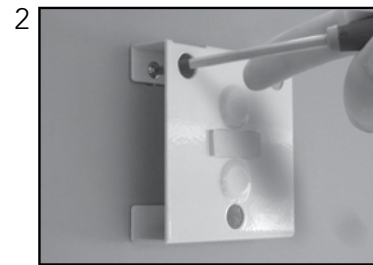
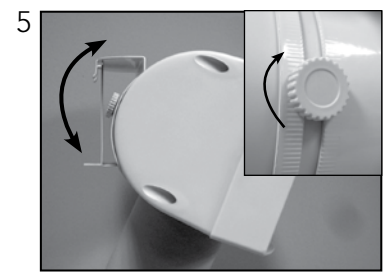
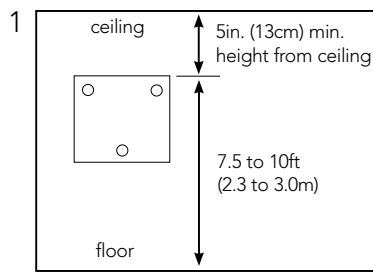

## TRIMMING COMBO CABLE

If necessary, you may trim the speaker cable portion of combo cable:

1. Separate speaker cable from sensor cable
2. Cut speaker cable **ONLY**.  
**DO NOT** cut sensor cable.
3. Coil excess sensor cable and place in wall plate.

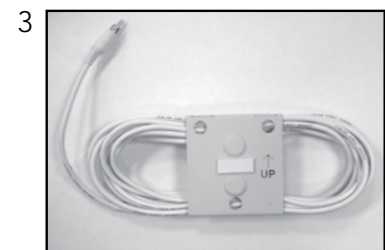
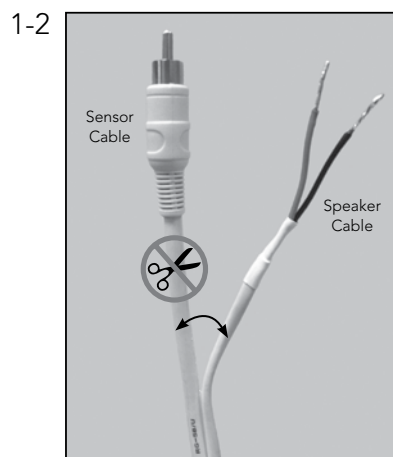

# Step 8: Install sensors

**(If you are using IR Speakers, skip to step 9)**

**Estimated time for this step: 10 minutes**

You're almost done.

## CEILING SENSOR

If you're installing a ceiling sensor and have an acoustic tile ceiling (or "drop ceiling"):

1. Locate the tile you marked in Step 2 for sensor placement.
2. Slide and twist the ceiling sensor bracket onto the T-bar rail until it rests on the rail or mount directly to the ceiling tile if not using the T-bar supports.
3. Attach the sensor to the cable leading to the receiver.
4. Replace the ceiling tile, making sure that the sides of the tiles prevent the sensor bracket from twisting.

### If you're installing a ceiling sensor and have a sheetrock ceiling:

1. Locate the spot you marked in Step 2 for sensor placement.
2. Mount the ceiling sensor directly to the sheetrock ceiling using the screws provided.
3. Attach the sensor to the cable leading to the receiver.

**NOTE:** If removing the bracket to mount sensor directly to metallic surface, use only non-metallic fasteners and supplied nylon washers to isolate sensor from surface. Failure to do so can introduce noise or damage the system.

T-bar support rail

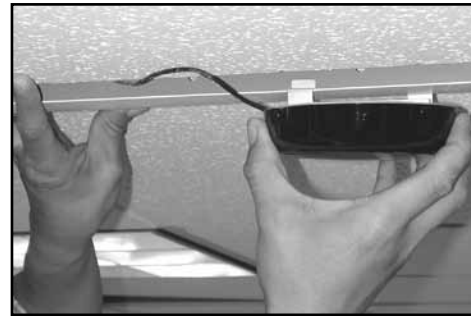

ceiling tile mount

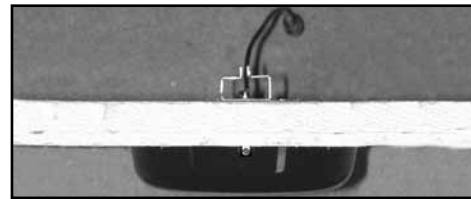

ceiling sensor features

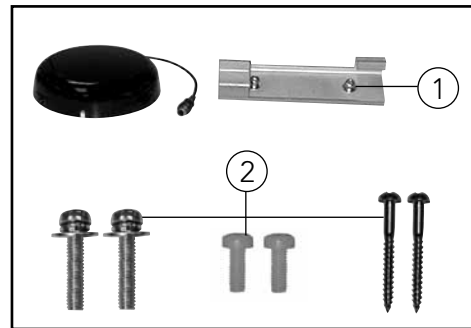

① ceiling tile mount bracket

② mounting screws

## WALL SENSOR

If you're installing wall sensors:

1. Locate the spots you marked in Step 2 for sensor placement.
2. Bend sensor bracket so that when placed on the wall, the sensor will face the center of the section of the room it's serving (see Step 2).
3. Slide bracket onto the back of the sensor.
4. Attach the sensor to the cable leading to the receiver.
5. Use mounting screws provided to secure bracket to wall.

You're done! Now it's time to test your setup.

wall sensor features

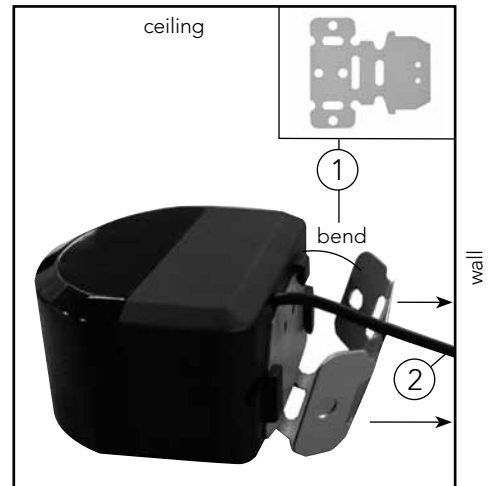

① wall sensor bracket (bent)

② sensor connector

# Step 9: Test system

## **Estimated time for this step: 5 minutes**

It's important to confirm that everything is working before packing up your tools. Take a few moments to test your work.

1. Use the following baseline settings to start:  
All volume controls at "10 o'clock".  
OptiVoice at Low.
2. Put on the microphone and turn it on.
3. Turn on the receiver.
4. Walk, talk, and listen to the sound quality (find another person to help you with this step: It's difficult to assess your own voice).
5. Try to find any areas where the receiver is not picking up your signal (see Appendix C if this happens).
6. Try to find any areas where you experience acoustic feedback (squealing). Turn down the volume in small increments until the feedback disappears.

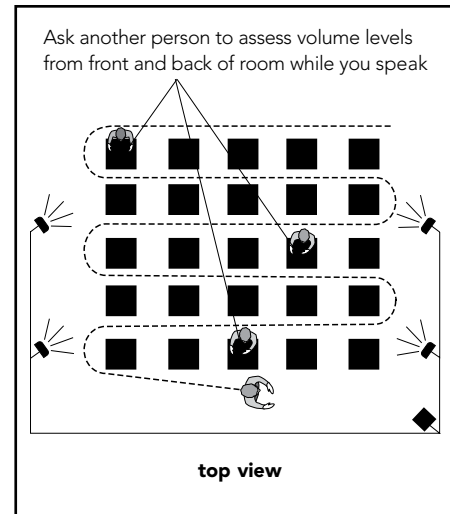

# Appendix A: Pro Digital Teacher's Tips

Your FrontRow Pro Digital has an energy-saving STANDBY mode.

The receiver will automatically go into STANDBY mode 10 minutes after you turn off or mute your microphone or stop playing a secondary audio source (computer, TV/DVD, CD, etc.)

The receiver will come out of STANDBY mode automatically when:

- You turn **on** and/or **un-mute** a microphone.
- You play an audio source connected to the receiver.

## Start of Day

1. Put microphone around neck and adjust strap so it is 5in (13cm) from your mouth
2. Turn microphone **on**. This will also take the receiver out of STANDBY mode.
3. Speak in a normal conversational tone. Adjust receiver volume to a comfortable level.

## End of Day

1. Turn microphone **off**. **Note:** Receiver will go into STANDBY mode automatically. You do not need to turn it **off**.
2. Charge overnight by plugging it into the charge cord on the back of the receiver.

## Battery Tip

Batteries cause the majority of troubleshooting problems. If your system doesn't appear to be working, try replacing the batteries with fresh cells first.

## Light Legend

### Microphone

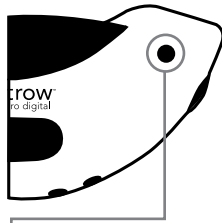

- Green..... Power On
- Blinking Green ... Muted
- Blinking Red..... Battery Low

### When Charging:

- Off ..... Alkaline Battery Detected
- Red ..... Charging
- Blinking Red..... Maintenance Charge

### Receiver

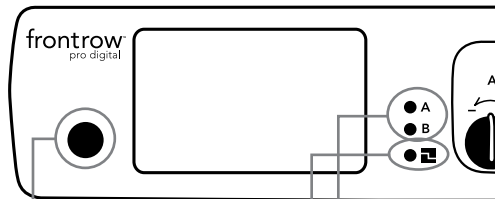

- Green..... Power On
- Yellow..... Standby
- Green.... Signal Received
- Red ..... No Signal/Muted
- Green.... Feedback suppression active

# Appendix B: Special speaker connections

## Using three speakers instead of four

If your room is too small for four speakers, connect three.

Connect speaker wires to the terminals as shown below for best power and sound distribution

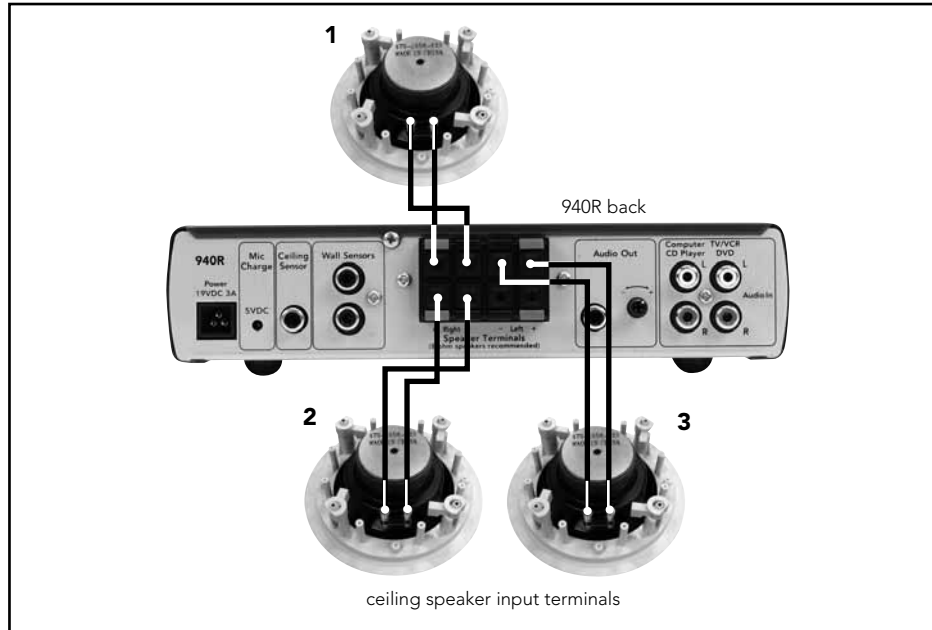

connection with 3-speaker connection grid

## Using up to six speakers:

If your room is too big for four speakers, daisy-chain six.

Connect speaker wires to the terminals as shown below for best power and sound distribution.

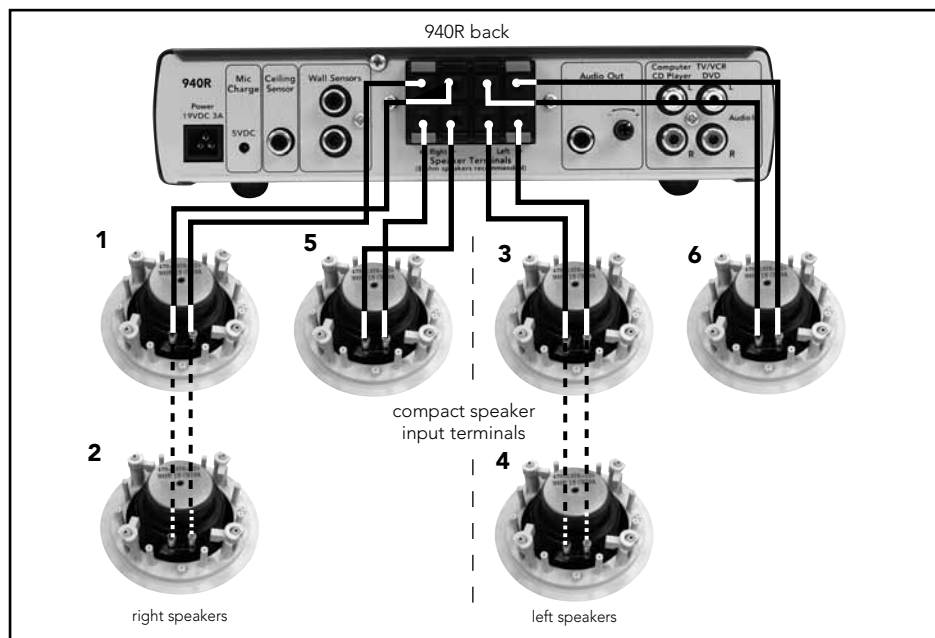

daisy chaining with 4 or 6-speaker connection grid

# Appendix C: Troubleshooting

## **I'm not getting reception — the channel lights on the receiver are red. What's wrong?**

- Check that the transmitter is on and is un-muted
  - Verify that you are not blocking either the emitters on the transmitter or the sensors on receiver or mounted around room
  - If reception is interrupted when facing a certain direction, install an additional sensor in that area of the room
  - If team-teaching, verify that transmitters are not on the same channel
  - Recharge transmitter's batteries if low battery indicator shows. Replace batteries if recharge is ineffective.
- 

## **I'm getting feedback (squealing) — how can I minimize this?**

- Make sure that speakers are mounted as close as possible to both the ceiling and the listeners; avoid mounting speakers in the teacher's primary lecture area (see **Step 2**)
  - Position the microphone closer to mouth
  - Lower the MIC VOLUME control(s) on the receiver
  - Select the Low or Medium OPTIVOICE setting
- 

## **There's no sound coming out of the speakers (or it's weak)**

- Verify that the receiver is on (green power light)
  - Verify that the receiver is picking up a signal (green channel indication light)
  - Increase the MIC VOLUME or AUX VOLUME control(s) on the receiver
  - Position the microphone closer to mouth
  - Verify that the speaker cables are connected properly
  - Verify that the transmitter is not muted
- 

## **My receiver won't turn on — the power light is off. What should I do?**

- Verify that the power supply is plugged into both the receiver and a working wall outlet
  - Test with another power supply
- 

## **The power light turned yellow**

- The receiver is in STANDBY mode. The power button will turn yellow in STANDBY mode.
  - The receiver will power-down automatically when it does not detect a microphone or audio input for more than 10 minutes.
  - The receiver will turn on automatically when:
    - You turn on and/or un-mute a microphone
    - You turn on an audio source connected to the receiver
- 

## **How can I eliminate 'dead spots' or microphone crackling / noise?**

- Verify that you are not blocking either the emitters on the transmitter or the sensors on receiver or mounted around room
  - If reception is interrupted when facing a certain direction, install an additional sensor in that area of the room (see **Step 2**)
  - If team-teaching, verify that transmitters are not on the same channel
  - Recharge or replace the transmitter's batteries
  - Verify that the emitter/mic is working (test with another working emitter/mic)
- 

## **Why do I need to install external sensors?**

Your FrontRow Pro Digital system uses infrared light to transmit your voice from the transmitter to the receiver, similar to how your remote control changes your TV channels. This light signal needs to either be direct (i.e., 'line of sight') or reflected off walls, ceiling, and other surfaces. While in many cases, the sensor that's built into the receiver is more than adequate, some classrooms don't have enough reflective surfaces to allow the teacher to turn away from the receiver or stand in certain parts of the room. That's why it's a good idea to add at least one external sensor.

---

## **I think I need more than four speakers. Can I?**

Yes. You can add up to 6 speakers (8Ω only) . See Special Speaker Connections (page 29)

**The receiver will not "wake up" from standby mode**

- The receiver will power-up automatically when:
  - Volume level on auxiliary audio device is set too low. Make sure microphone is on and working correctly, and the receiver is receiving the signal. The receiver keeps going into standby mode when playing auxiliary audio - Volume level on auxiliary audio device is set too low.
- 

**Adapto LED keeps flashing on and off**

- This is normal. The light will turn on when the Adapto platform is processing the speech signal. There is nothing you need to do.
- 

**High or low pitched whine or hum coming through speakers**

- There may be a ground loop with the system. Install a ground loop isolator.
  - There may be "noisy" electrical wiring. Install an AC line filter.
- 

**Sensor lights are blinking**

- This is normal. When the 940R is in standby mode the sensor LED's will blink every two seconds.

# frontrow™

FRONTROW is a division of



## **USA/Global**

FrontRow  
Corporate Headquarters  
2080 Lakeville Highway  
Petaluma, CA 94954-6713  
toll-free: 800.227.0735  
tel: 707.769.1110  
fax: 707.769.9624  
web: [www.gofrontrow.com](http://www.gofrontrow.com)

## **Canada**

FrontRow  
6950 Creditview Road, Unit 1  
Mississauga, ON L5N 0A6  
toll-free: 800.340.9894  
tel: 905.461.5300  
fax: 905.677.7760  
web: [www.gofrontrow.com](http://www.gofrontrow.com)

## **New Zealand**

Oticon New Zealand Ltd.  
142 Lambton Quay  
P.O. Box 9128  
Te Aro, Wellington  
toll-free: 800 OTICON  
toll-free fax: 00800 FAX OTICON  
web: [www.oticon.co.nz](http://www.oticon.co.nz)

## **Australia**

Phonic Ear  
12/97 Castlemaine Street  
Milton Qld 4064  
Australia  
freecall: 1 800 PHONIC  
fax: 1300 746 642  
web: [www.gofrontrow.com.au](http://www.gofrontrow.com.au)

## **Scandinavia**

Phonic Ear A/S  
Kongebakken 9  
2765 Smørum  
Denmark  
tel: +45 3917 7101  
fax: +45 3927 7900  
web: [www.gofrontrow.com](http://www.gofrontrow.com)  
[www.phonicear.com](http://www.phonicear.com)

## **United Kingdom**

PC Werth Limited  
Audiology House  
45 Nightingale Lane  
London SW12 8SP  
tel: 020 8772 2700  
web: [www.soundfield.info](http://www.soundfield.info)